



CC9800 | Crawler Crane 1600 t Lifting Capacity



CC9800

CRAWLER CRANE





HIGHLIGHTS

CC9800

HIGHLIGHTS

- Max. capacity 1600 t
 - Max. load moment 26930 mt
 - Superlift radii 19-30 m
 - Excellent capacities at the luffing fly jib
 - Redundant drivelines
 - 400 V power supply
-
- Max. Tragfähigkeit 1600 t
 - Max. Lastmoment 26930 mt
 - Superliftradien 19-30 m
 - Ausgezeichnete Tragfähigkeiten am wippbaren Hilfsausleger
 - Redundante Antriebseinheiten
 - 400 V Stromaggregat
-
- Capacité maximale de 1600 t
 - Moment de charge maximum 26930 mt
 - Radius superlift 19-30 m
 - Excellentes capacités avec la volée variable
 - Double unité d'entraînement
 - Groupe électrogène de 400 V

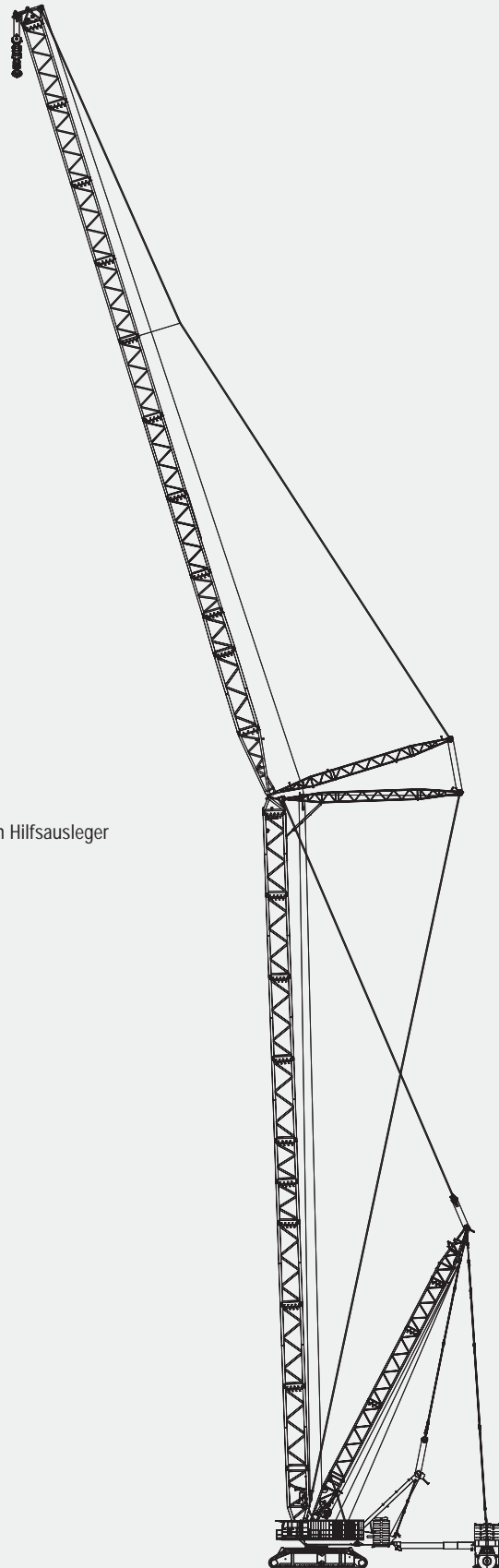

CC9800
 CRAWLER CRANE

CONTENTS · INHALT · CONTENU

Page · Seite · Page:

Specifications · Technische Daten · Caractéristiques

Specifications · Technische Daten · Caractéristiques	4
Superlift configurations · Superlift-Konfigurationen · Combinaisons Superlift	7
Specifications · Technische Daten · Caractéristiques	8
Boom combinations · Ausleger-Kombinationen · Combinaisons de flèche	10

1

Main boom · Hauptausleger · Flèche principale

Working ranges with Superlift · Arbeitsbereiche mit Superlift · Portées avec Superlift (SSL, SSL/LSL)	12
Lifting capacities with Superlift · Tragfähigkeiten mit Superlift · Capacités de levage avec Superlift (SSL, SSL/LSL)	13

2

Fixed fly jib · Starrer Hilfsausleger · Fléchette fixe

Working ranges with Superlift, 20° · Arbeitsbereiche mit Superlift, 20° · Portées avec Superlift, 20° (SSL/LSL + LF)	16
Lifting capacities with Superlift · Tragfähigkeiten mit Superlift · Capacités de levage avec Superlift (SSL/LSL + LF)	17

3

Luffing fly jib · Wippbarer Hilfsausleger · Fléchette à volée variable

Working ranges with SL · Arbeitsbereiche mit SL · Portées avec SL (SWSL)	18
Lifting capacities with Superlift · Tragfähigkeiten mit Superlift · Capacités de levage avec Superlift (SWSL / SFSL 15°)	19

4

Fixed fly jib · Starrer Hilfsausleger · Fléchette fixe

Working ranges with SL · Arbeitsbereiche mit SL · Portées avec SL (SFVL)	50
Lifting capacities with SL · Tragfähigkeiten mit SL · Capacités de levage avec SL (SFVL)	51

5

Technical description · Technische Beschreibung · Descriptif technique

Crawler carrier · Superstructure · Optional equipment	52
Boom configurations · Optional equipment	53
Raupenunterwagen · Oberwagen · Zusatzausrüstung	54
Auslegervarianten · Zusatzausrüstung	55
Châssis à chenilles · Partie supérieure · Equipements optionnels	56
Combinaisons de flèche · Equipements optionnels	57

6





SPECIFICATIONS · TECHNISCHE DATEN · CARACTÉRISTIQUES

WORKING SPEEDS (INFINITELY VARIABLE) · ARBEITSGESCHWINDIGKEITEN (STUFENLOS REGELBAR) · VITESSES DE TRAVAIL (RÉGLABLES SANS PALIERS)

Mechanisms Antriebe Mécanismes	Rope \varnothing Seil- \varnothing \varnothing du câble	Speeds ¹⁾ Geschwindigkeiten ¹⁾ Vitesses ¹⁾	Single line pull Seilzug je Strang Effort sur brin simple	Length of hoist rope Länge des Hubseils Longueur du câble de levage
Hoist I+II (H1+H2) Hubwerk I+II (H1+H2) Treuil de levage I+II (H1+H2)	40 mm	max. 120 m / min	352 kN / 316 kN ²⁾	1540 m
Runner winch R (H3) – option Runnerwinde R (H3) – Option Tambour potence R (H3) – option	40 mm	max. 90 m / min	352 kN	700 m
Boom derricking (W2) Wippwerk Hauptausleger (W2) Variation de flèche (W2)	40 mm	max. 120 m / min		
Boom hoist (E) Einziehwerk (E) Relevage de flèche (E)	40 mm	max. 40 m / min		
Jib luffing (W1) Wippwerk Hilfsausleger (W1) Variation de volée (W1)	40 mm	max. 105 m / min		
Slewing (rpm) Drehwerk (U/min) Orientation (tr/mn)		0 – 0,6 ¹ /min		

1) top layers · oberste Lagen · couches supérieures

2) without / with reeving effect considered · Angabe ohne / mit Wirkungsgrad der Einscherung · sans / avec effort de mouflage

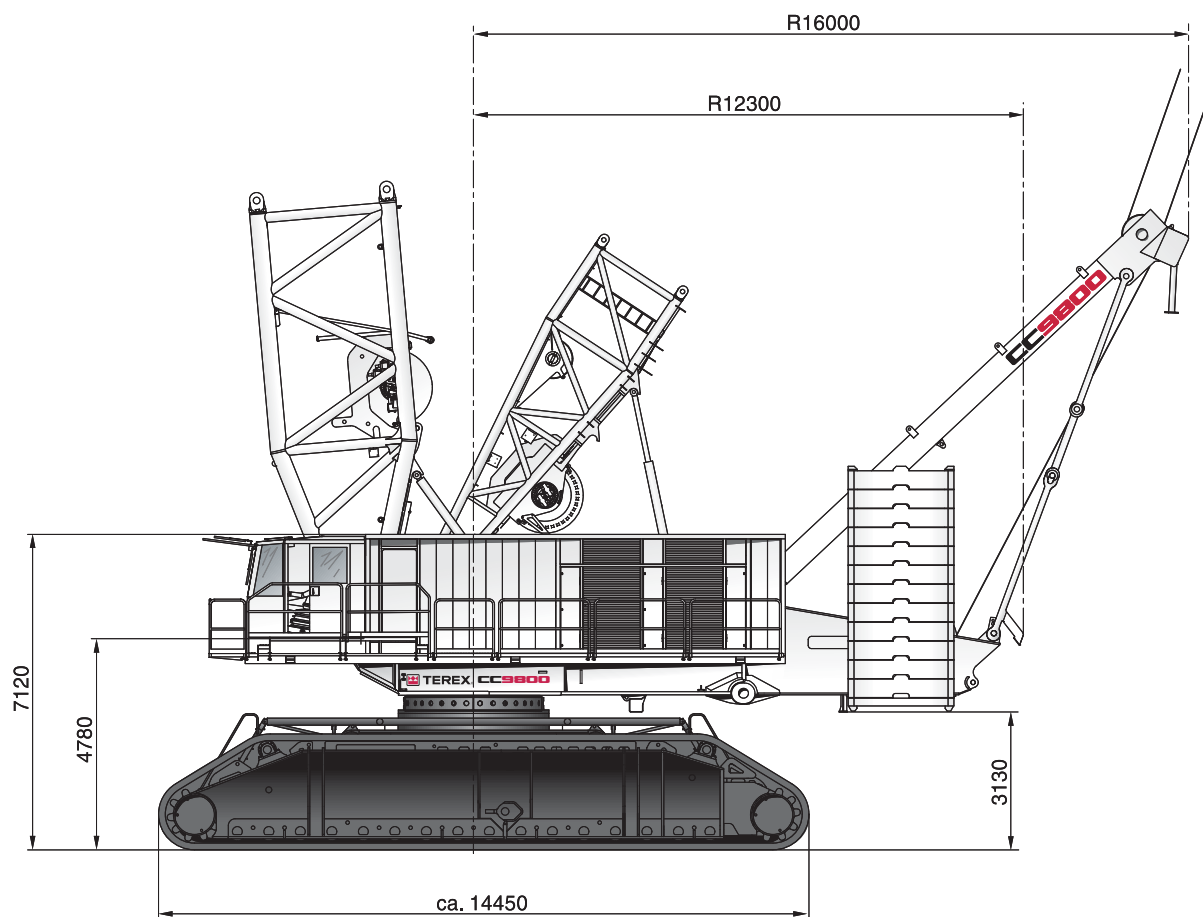



CC9800
CRAWLER CRANE

SPECIFICATIONS · TECHNISCHE DATEN · CARACTÉRISTIQUES

CARRIER PERFORMANCE · FAHRLEISTUNGEN · PERFORMANCES DU PORTEUR

1 st gear · 1. Gang · 1 ^{ère} vitesse	max. 0,4 km/h
2 nd gear · 2. Gang · 2 ^{ème} vitesse	max. 0,8 km/h

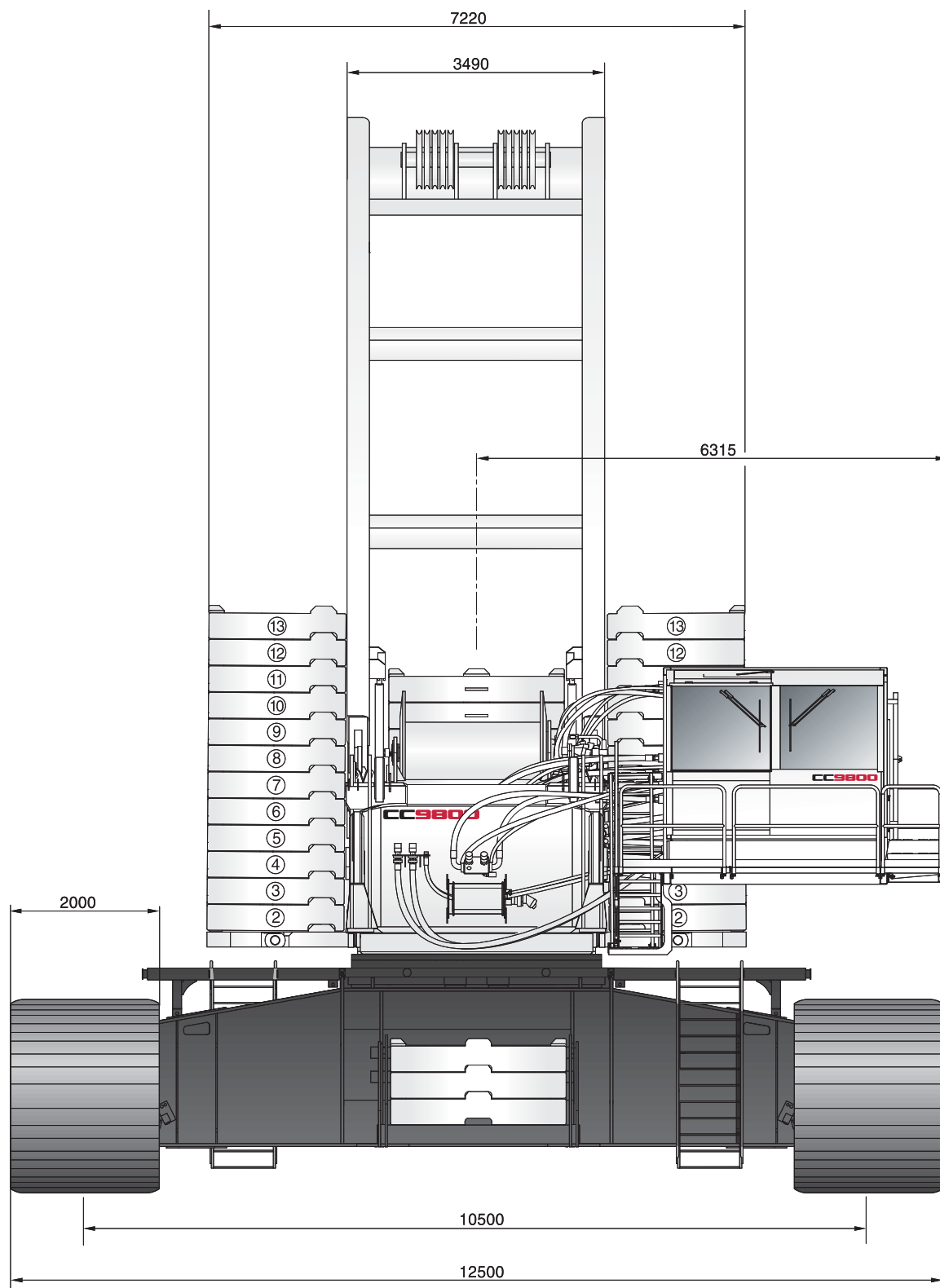

1





SPECIFICATIONS · TECHNISCHE DATEN · CARACTÉRISTIQUES

HOOK BLOCK SYSTEM · UNTERFLASCHENSYSTEM · SYSTÈME DE CROCHET-MOUFLE

Type Typ Type	Possible load Mögliche Traglast Charge possible	Number of sheaves Anzahl der Rollen Nombre de poulies	Number of lines Strangzahl Nombre de brins	Weight Gewicht Poids	„D“
2 x 800	1600 t	2 x 13	2 x 26	44 000 kg	8,70 m
	800 t	2 x 7	2 x 12	28 000 kg / 18 000 kg	6,50 m
	800 t	1 x 13	2 x 12	28 000 kg / 18 000 kg	6,20 m
	495 t	1 x 7	1 x 14	22 000 kg / 8 500 kg	6,50 m
100	100 t	1 x 1	1 x 3	7 700 kg / 3 700 kg	4,50 m

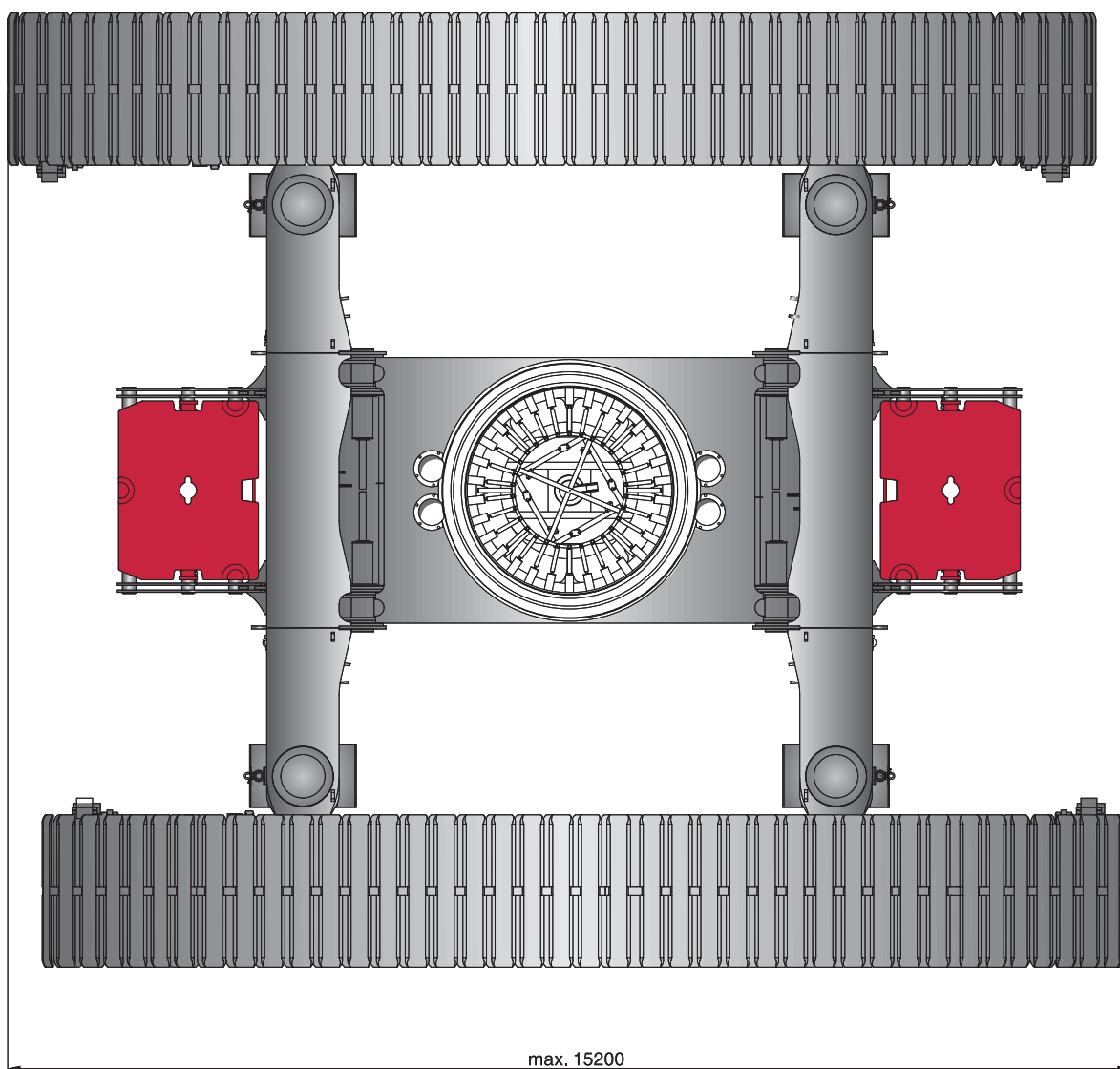



CC9800
CRAWLER CRANE

**SUPERLIFT CONFIGURATIONS · SUPERLIFT-KONFIGURATIONEN ·
COMBINAISONS SUPERLIFT**

STANDARD SUPERLIFT ATTACHMENT · SERIENMÄSSIGE SUPERLIFTEINRICHTUNG ·
SUPERLIFT DE SÉRIE

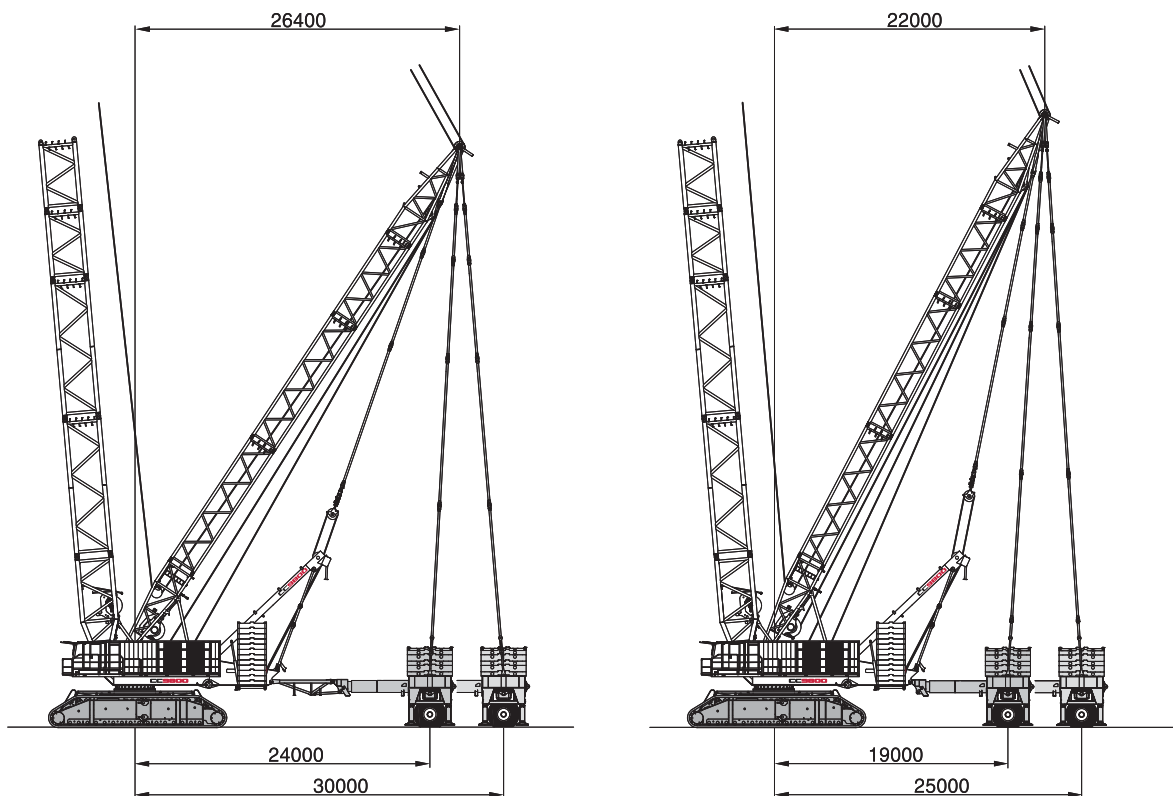

VARIABLE SUPERLIFT ATTACHMENT · VARIABLE SUPERLIFTEINRICHTUNG · SUPERLIFT VARIABLE

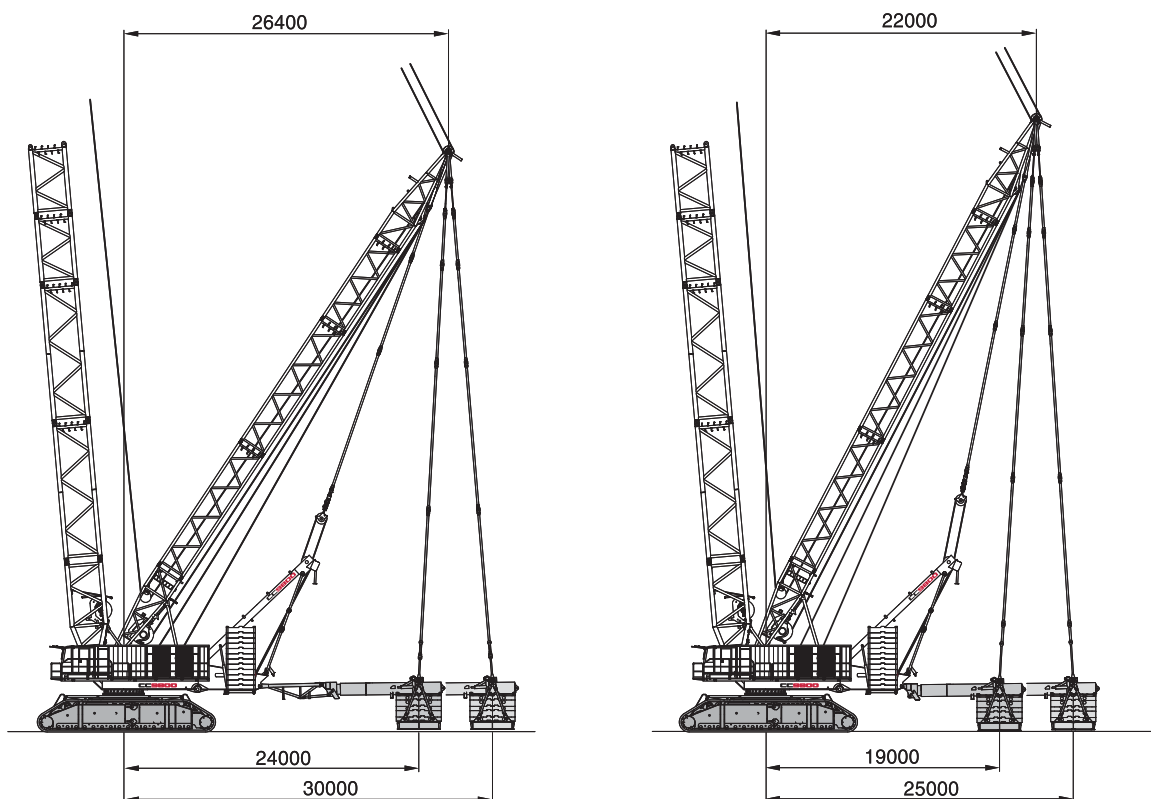

CC9800





SPECIFICATIONS · TECHNISCHE DATEN · CARACTÉRISTIQUES

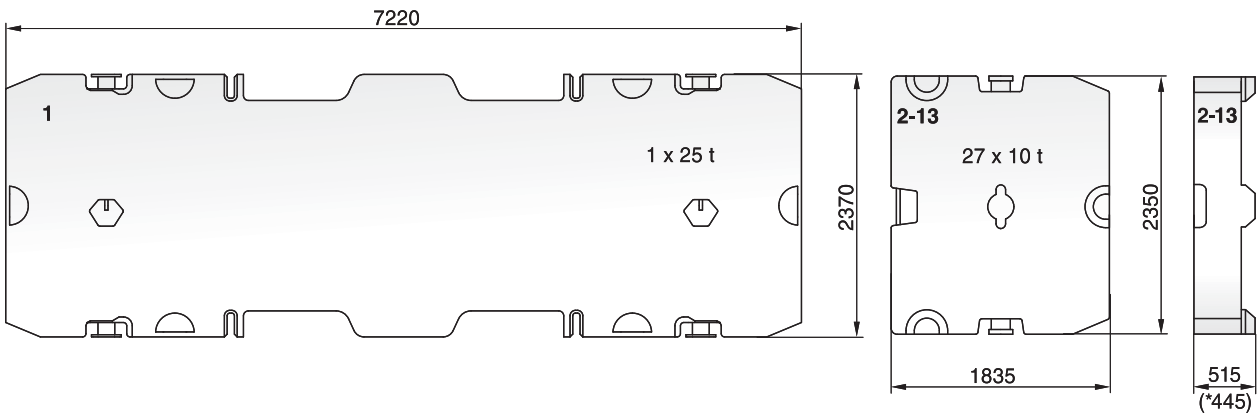
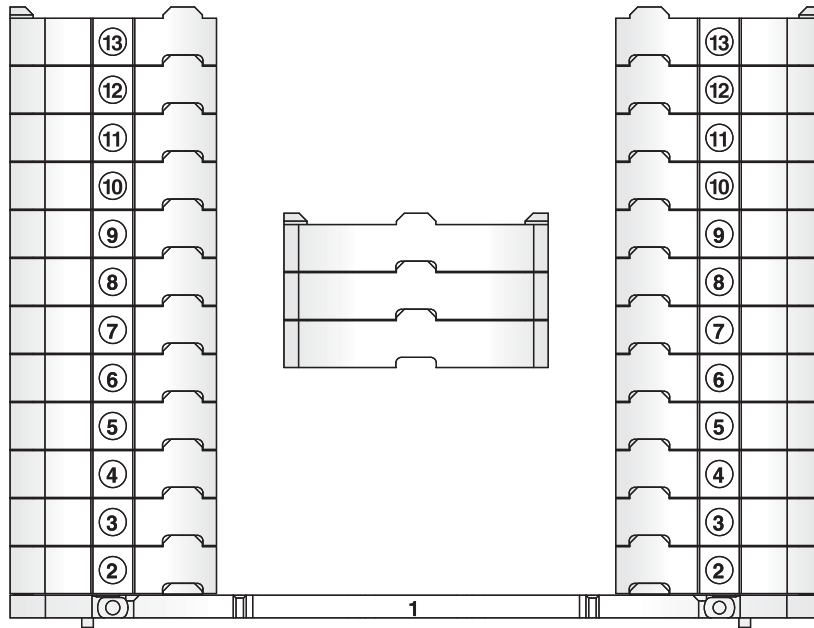

* Option

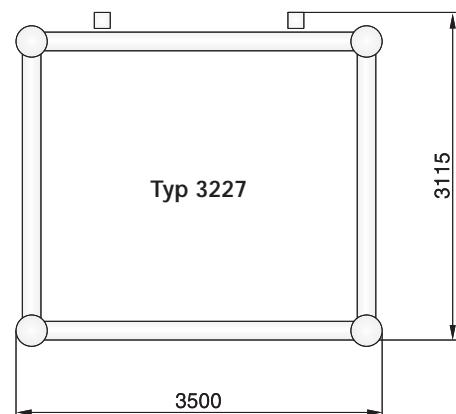
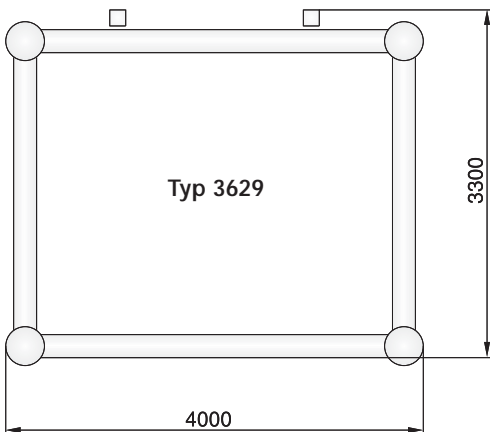



CC9800
CRAWLER CRANE

SPECIFICATIONS · TECHNISCHE DATEN · CARACTÉRISTIQUES

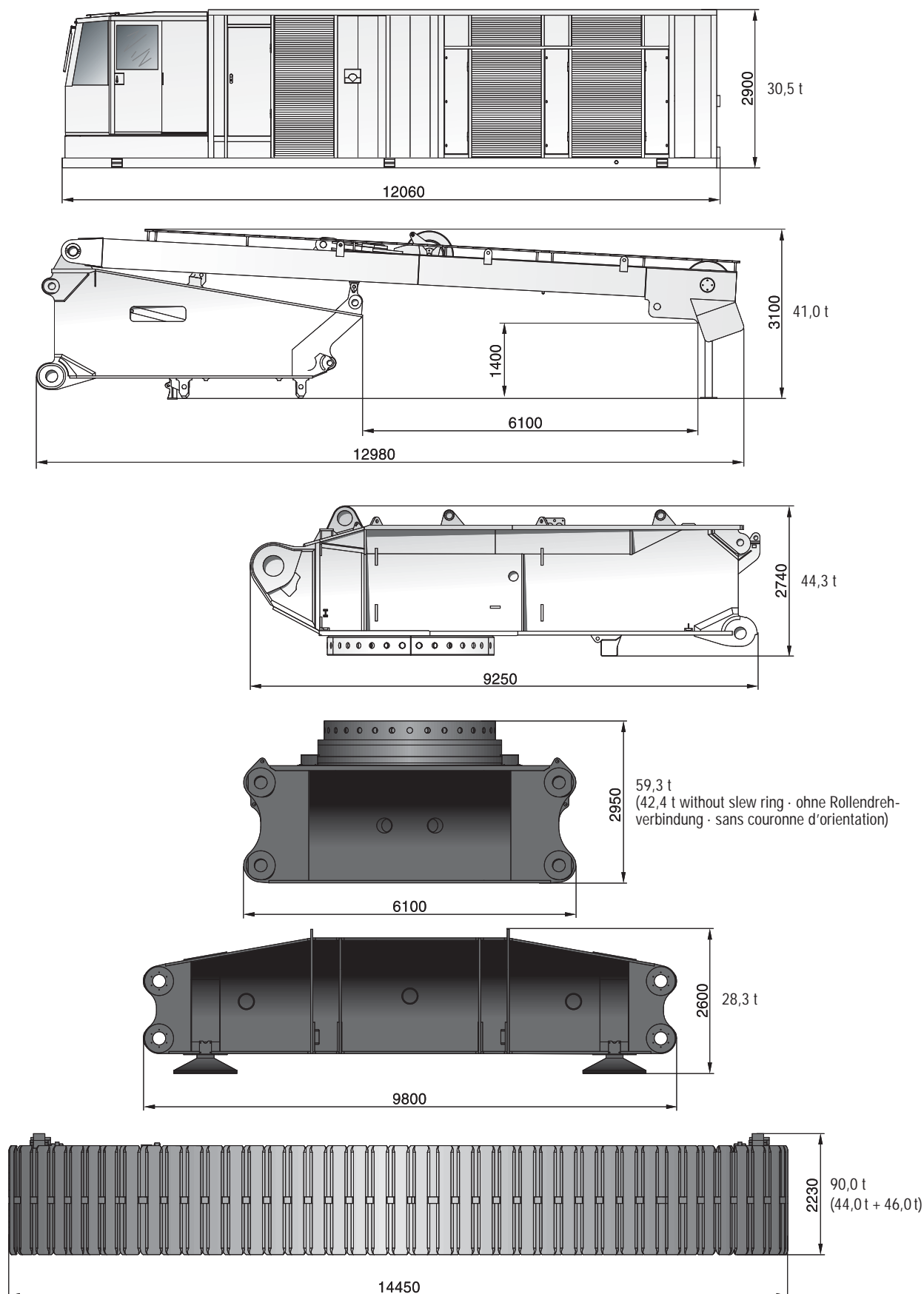



BOOM COMBINATIONS · AUSLEGER-KOMBINATIONEN · COMBINAISONS DE FLÈCHE

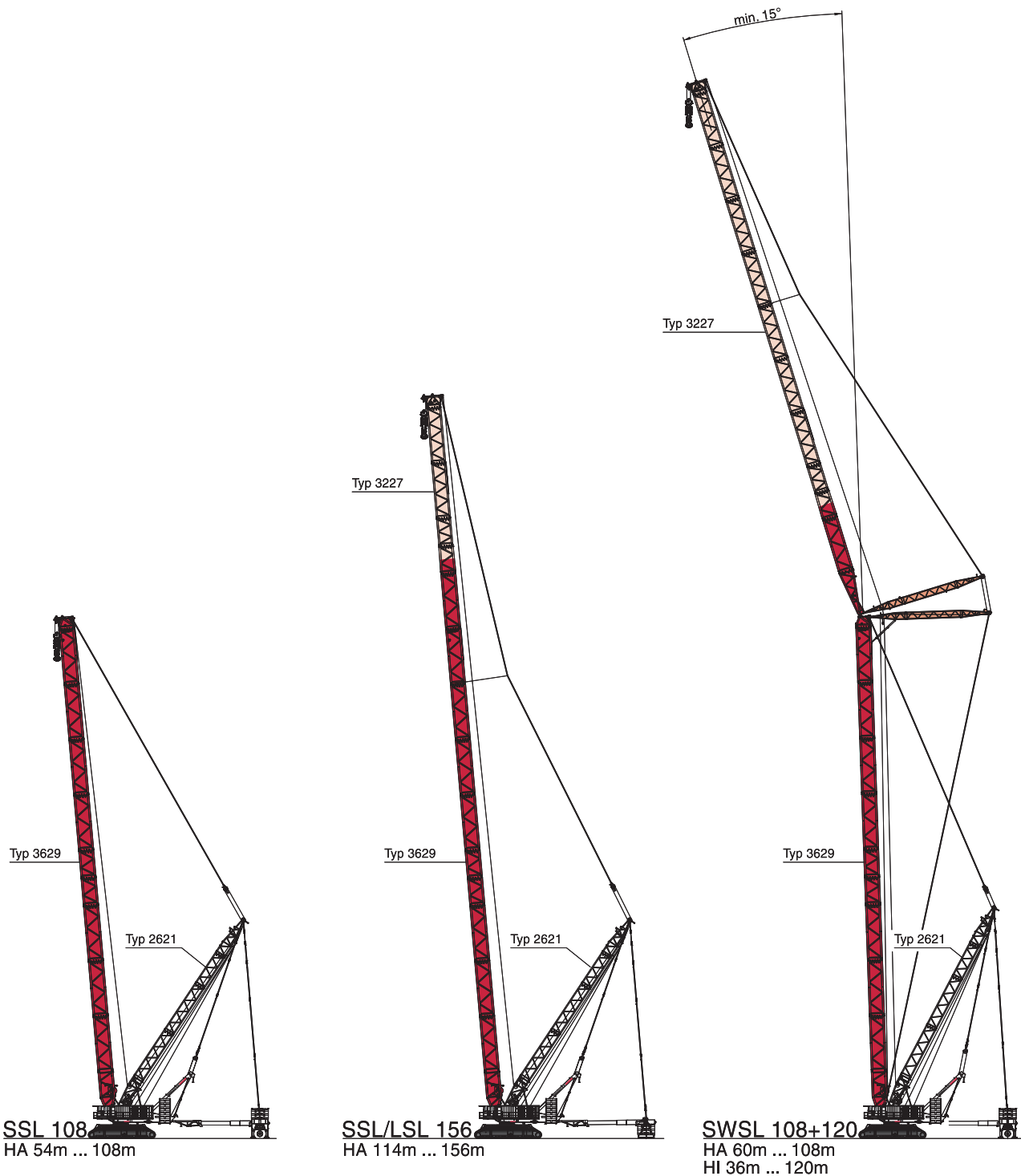



BOOM COMBINATIONS · AUSLEGER-KOMBINATIONEN · COMBINAISONS DE FLÈCHE

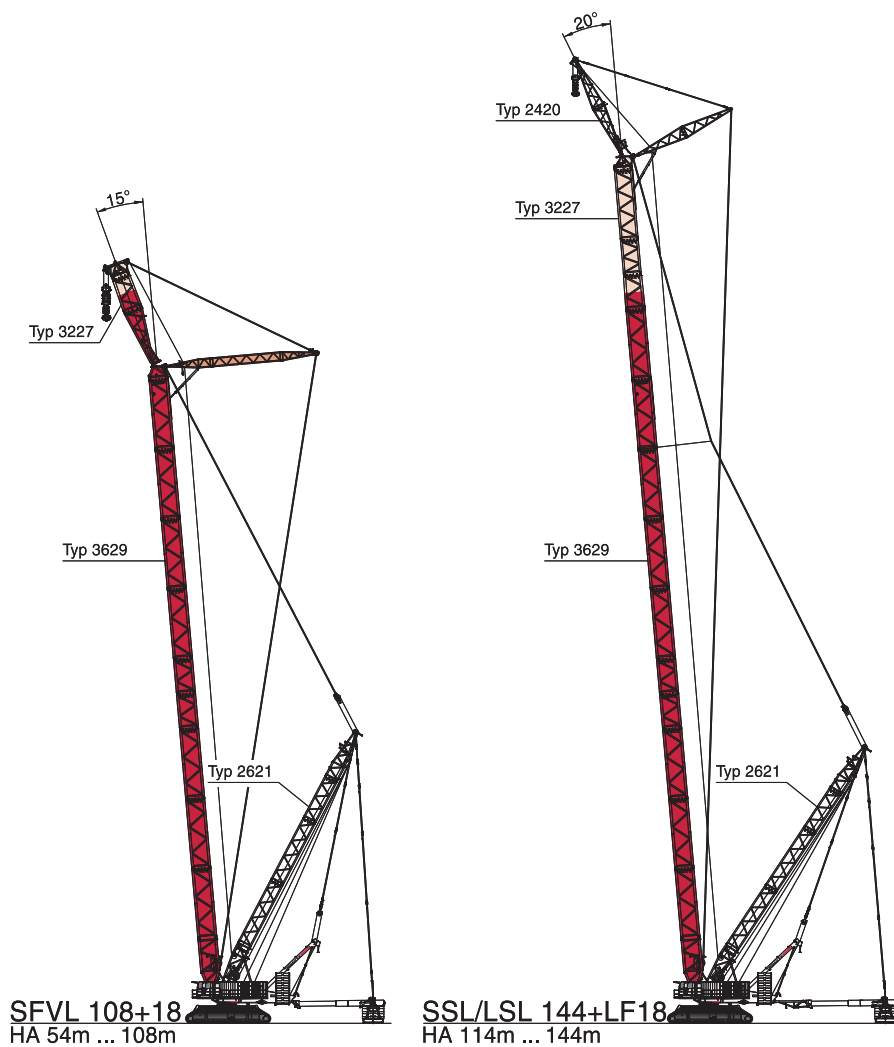



SSL, SSL / LSL WORKING RANGES · ARBEITSBEREICHE · PORTÉES

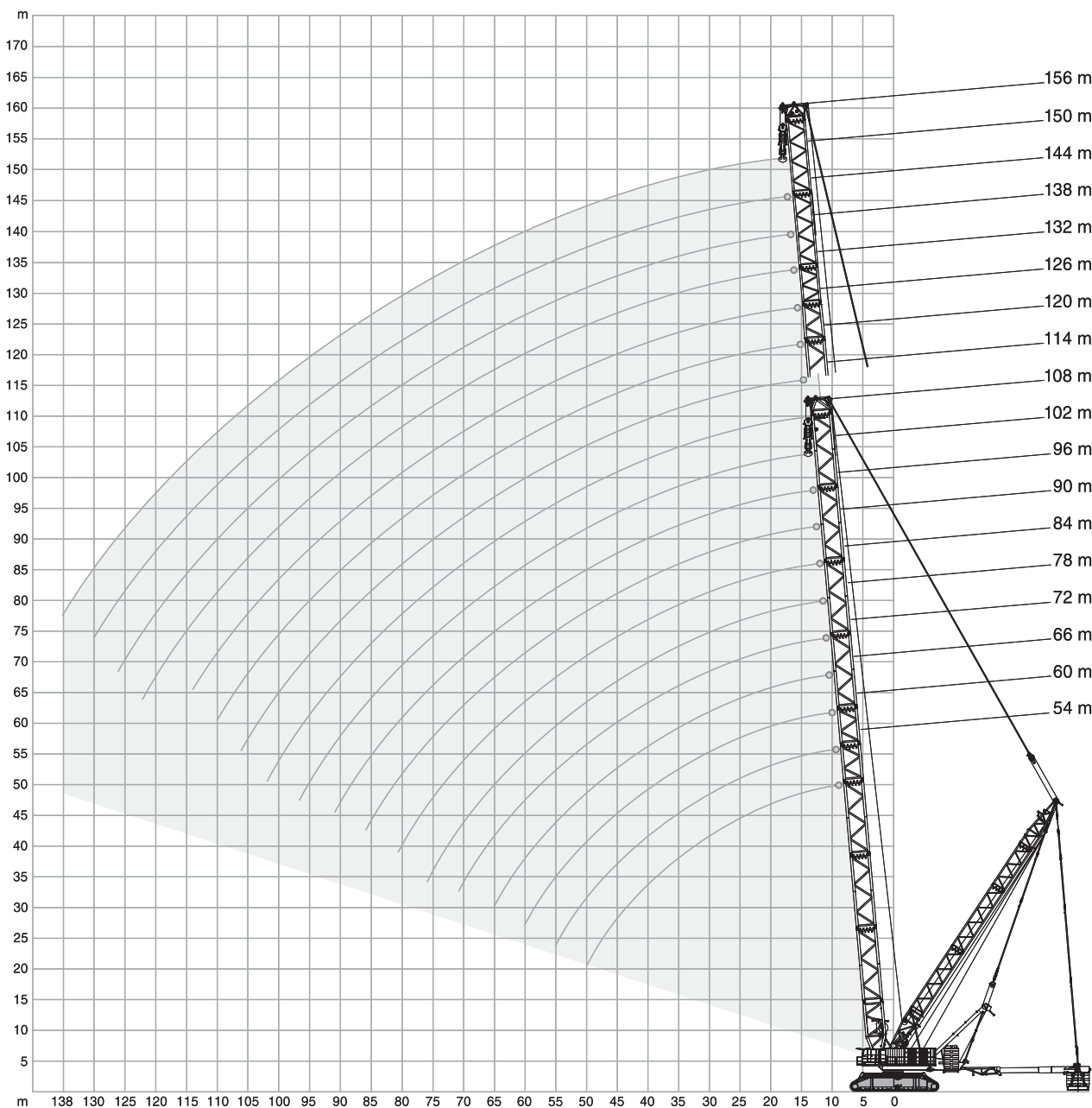



SSL LIFTING CAPACITIES · TRAGFÄHIGKEITEN · CAPACITÉS DE LEVAGE

295 t + 60 t ZB 19-30 m 10,50 m 360° ISO

m	54 m		60 m		66 m		72 m		78 m		m
	0 t	0t-800t	0 t	0t-800t	0 t	0t-800t	0 t	0t-800t	0 t	0t-800t	
10	842,0	1600,0	795,0	1579,0	-	-	-	-	-	-	10
11	762,0	1549,5	722,0	1543,5	679,0	1522,0	645,0	1351,0	-	-	11
12	682,0	1520,0	649,0	1508,0	617,0	1499,0	588,0	1351,0	560,0	1234,0	12
14	571,0	1447,0	545,0	1435,0	521,0	1426,0	497,0	1351,0	475,0	1234,0	14
16	488,0	1380,0	467,0	1369,0	447,0	1360,0	428,0	1351,0	410,0	1234,0	16
18	424,0	1319,0	407,0	1307,0	390,0	1299,0	374,0	1290,0	358,0	1234,0	18
20	368,0	1263,0	359,0	1251,0	344,0	1242,0	330,0	1234,0	316,0	1227,0	20
22	316,0	1211,0	311,0	1199,0	306,0	1191,0	294,0	1183,0	282,0	1175,0	22
24	275,0	1122,0	270,0	1115,0	266,0	1110,0	263,0	1105,0	252,0	1100,0	24
26	242,0	1032,0	237,0	1025,0	233,0	1019,0	230,0	1015,0	227,0	1010,0	26
28	215,0	936,0	210,0	948,0	206,0	942,0	203,0	938,0	200,0	933,0	28
30	192,0	849,0	187,0	880,0	183,0	875,0	180,0	870,0	177,0	866,0	30
34	157,0	712,0	151,0	751,0	147,0	764,0	144,0	759,0	141,0	755,0	34
38	130,0	605,0	124,0	641,0	120,0	669,0	116,0	671,0	112,0	667,0	38
42	110,0	528,0	103,0	548,0	97,5	580,0	93,5	599,0	89,5	595,0	42
46	93,5	448,0	86,0	483,0	80,5	502,0	76,0	526,0	71,5	536,0	46
50	80,5	376,0	72,5	422,0	66,5	436,0	61,5	461,0	57,0	477,0	50
54	-	-	62,0	360,0	55,5	396,0	50,0	404,0	45,4	422,0	54
55	-	-	59,5	346,0	53,2	382,7	47,6	391,2	42,9	409,7	55
58	-	-	-	-	46,6	343,0	40,7	359,0	35,6	373,0	58
60	-	-	-	-	42,9	318,0	36,8	341,5	31,5	351,0	60
62	-	-	-	-	-	-	33,0	324,0	27,5	329,0	62
65	-	-	-	-	-	-	28,3	292,0	22,4	307,0	65
66	-	-	-	-	-	-	-	-	20,8	301,0	66
70	-	-	-	-	-	-	-	-	-	267,0	70
71	-	-	-	-	-	-	-	-	-	258,0	71

m	84 m		90 m		96 m		102 m		108 m		m
	0 t	0t-800t	0 t	0t-800t	0 t	0t-800t	0 t	0t-800t	0 t	0t-800t	
12	534,0	1115,0	-	-	-	-	-	-	-	-	12
13	494,0	1115,0	471,0	1085,0	449,0	980,0	-	-	-	-	13
14	454,0	1115,0	436,0	1085,0	416,0	980,0	399,0	870,0	381,0	806,0	14
16	392,0	1115,0	377,0	1085,0	361,0	980,0	346,0	870,0	330,0	806,0	16
18	343,0	1115,0	330,0	1085,0	316,0	980,0	303,0	870,0	289,0	806,0	18
20	303,0	1115,0	292,0	1085,0	279,0	980,0	267,0	870,0	255,0	806,0	20
22	269,0	1115,0	260,0	1045,0	248,0	978,0	238,0	870,0	226,0	806,0	22
24	241,0	1087,0	232,0	1012,0	221,0	945,0	212,0	870,0	202,0	806,0	24
26	217,0	1006,0	209,0	979,0	199,0	910,0	190,0	855,0	181,0	790,0	26
28	196,0	928,0	189,0	923,0	179,0	884,0	171,0	826,0	162,0	772,0	28
30	174,0	861,0	171,0	856,0	162,0	852,0	154,0	808,0	146,0	749,0	30
34	137,0	750,0	133,0	745,0	129,0	741,0	126,0	738,0	118,0	719,0	34
38	108,0	662,0	103,0	657,0	100,0	653,0	98,5	650,0	92,5	644,0	38
42	85,0	590,0	81,0	586,0	77,5	581,0	75,5	579,0	69,5	572,0	42
46	67,0	531,0	63,0	527,0	59,0	522,0	57,0	520,0	51,0	513,0	46
50	52,5	482,0	48,4	477,0	44,4	473,0	42,3	470,0	36,3	463,0	50
54	40,6	433,0	36,2	435,0	32,2	430,0	29,9	428,0	23,9	421,0	54
55	38,0	421,2	33,6	424,5	29,6	421,0	27,2	418,6	21,1	411,0	55
57	33,0	397,7	28,6	403,5	24,4	403,0	21,9	400,0	-	393,0	57
58	30,5	386,0	26,1	393,0	21,9	394,0	-	391,0	-	384,0	58
60	26,3	364,5	21,6	373,0	-	376,0	-	375,0	-	368,5	60
62	22,1	343,0	-	353,0	-	358,0	-	359,0	-	353,0	62
63	20,2	333,0	-	343,7	-	349,0	-	351,0	-	346,0	63
66	-	305,0	-	316,0	-	322,0	-	327,0	-	325,0	66
70	-	274,0	-	283,0	-	290,0	-	296,0	-	295,0	70
74	-	251,0	-	252,0	-	261,0	-	268,0	-	268,0	74
76	-	235,0	-	240,5	-	247,0	-	255,0	-	255,5	76
78	-	-	-	232,0	-	233,0	-	242,0	-	243,0	78
81	-	-	-	215,0	-	215,0	-	223,2	-	225,0	81
82	-	-	-	-	-	211,0	-	217,0	-	220,0	82
86	-	-	-	-	-	195,0	-	194,0	-	198,0	86
90	-	-	-	-	-	-	-	181,0	-	177,0	90
91	-	-	-	-	-	-	-	178,0	-	172,0	91
94	-	-	-	-	-	-	-	-	-	163,0	94
97	-	-	-	-	-	-	-	-	-	154,0	97





SSL / LSL LIFTING CAPACITIES · TRAGFÄHIGKEITEN · CAPACITÉS DE LEVAGE

295 t + 60 t ZB		19-30 m		10,50 m		360°		ISO			
114 m		120 m		126 m		132 m		138 m			
0 t 0t-800t		0 t 0t-800t		0 t 0t-800t		0 t 0t-800t		0 t 0t-800t			
m	t	t	t	t	t	t	t	t	t	m	
16	319,0	684,0	307,0	619,0	293,0	571,0	281,0	518,0	-	16	
18	281,0	684,0	271,0	619,0	258,0	571,0	248,0	518,0	238,0	474,0	18
20	249,0	684,0	241,0	619,0	228,0	571,0	219,0	518,0	210,0	474,0	20
22	222,0	684,0	215,0	619,0	203,0	571,0	195,0	518,0	187,0	474,0	22
24	199,0	684,0	192,0	619,0	182,0	571,0	174,0	518,0	167,0	474,0	24
26	179,0	680,0	173,0	619,0	163,0	571,0	156,0	518,0	149,0	474,0	26
28	162,0	667,0	156,0	611,0	146,0	569,0	140,0	518,0	133,0	474,0	28
30	146,0	654,0	141,0	602,0	132,0	561,0	125,0	514,0	119,0	473,0	30
34	120,0	630,0	116,0	583,0	107,0	545,0	101,0	502,0	96,0	463,0	34
38	97,5	600,0	95,5	563,0	87,0	529,0	82,0	489,0	76,5	452,0	38
42	75,0	562,0	74,0	533,0	69,0	503,0	65,5	475,0	60,5	442,0	42
46	57,0	505,0	56,0	503,0	51,0	477,0	49,1	451,0	45,5	423,0	46
50	42,6	456,0	41,3	455,0	36,3	449,0	34,3	428,0	30,6	404,0	50
54	30,5	415,0	29,1	413,0	24,0	408,0	21,9	405,0	-	384,0	54
58	20,3	380,0	-	378,0	-	372,0	-	370,0	-	363,0	58
62	-	349,0	-	347,0	-	341,0	-	339,0	-	332,0	62
66	-	322,0	-	320,0	-	314,0	-	312,0	-	305,0	66
70	-	298,0	-	296,0	-	290,0	-	287,0	-	281,0	70
74	-	272,0	-	273,0	-	268,0	-	264,0	-	258,0	74
78	-	249,0	-	251,0	-	247,0	-	245,0	-	240,0	78
82	-	228,0	-	230,0	-	227,0	-	225,0	-	221,0	82
86	-	208,0	-	211,0	-	208,0	-	207,0	-	204,0	86
90	-	189,0	-	193,0	-	191,0	-	191,0	-	188,0	90
94	-	171,0	-	176,0	-	175,0	-	175,0	-	173,0	94
98	-	154,0	-	160,0	-	159,0	-	160,0	-	159,0	98
102	-	145,0	-	144,0	-	144,0	-	146,0	-	145,0	102
106	-	-	-	134,0	-	130,0	-	133,0	-	133,0	106
110	-	-	-	-	-	119,0	-	120,0	-	121,0	110
114	-	-	-	-	-	-	-	108,0	-	109,0	114
118	-	-	-	-	-	-	-	-	-	97,5	118
122	-	-	-	-	-	-	-	-	-	91,0	122

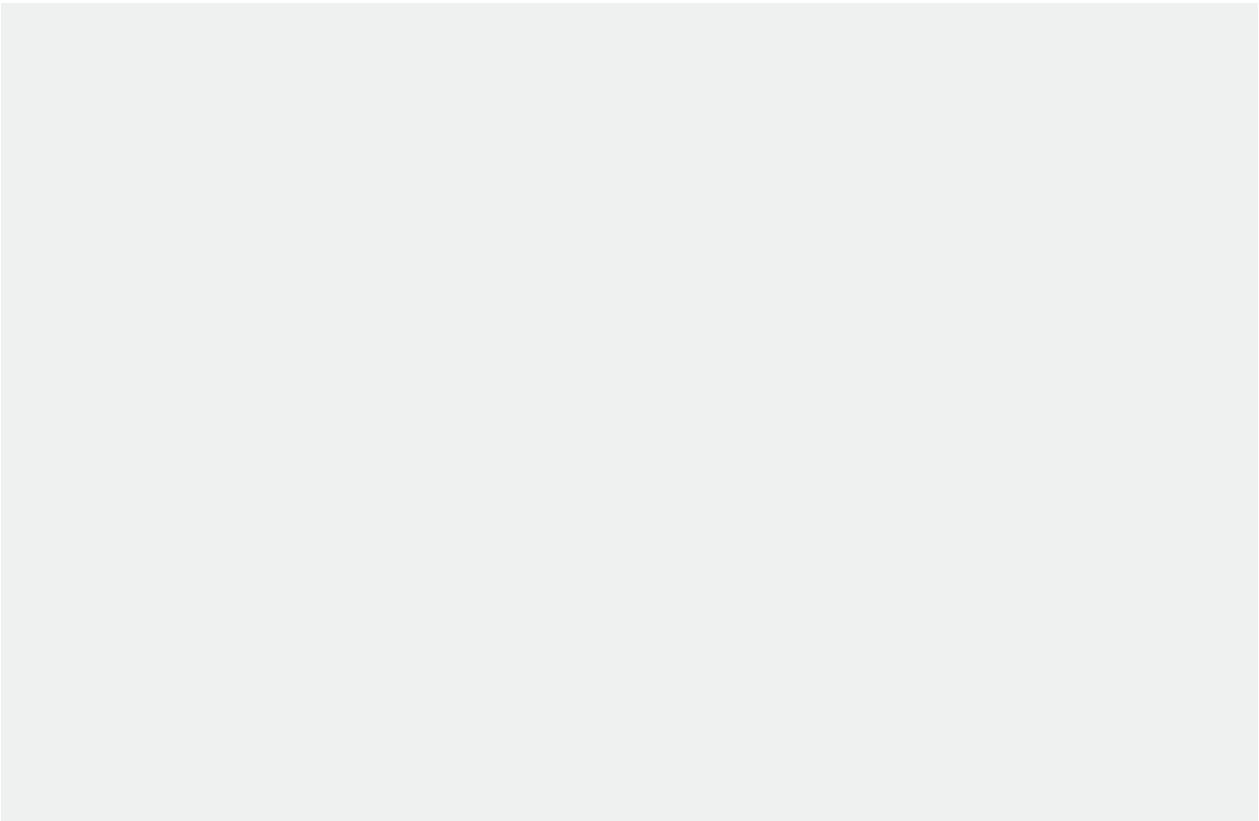



SSL / LSL LIFTING CAPACITIES · TRAGFÄHIGKEITEN · CAPACITÉS DE LEVAGE

295 t + 60 t ZB 19-30 m 10,50 m 360° ISO

m	144 m		150 m		156 m		m
	0 t	0t-800t	0 t	0t-800t	0 t	0t-800t	
18	229,0	430,0	222,0	391,0	214,0	353,0	18
20	202,0	430,0	197,0	391,0	189,0	353,0	20
22	180,0	430,0	175,0	391,0	168,0	353,0	22
24	160,0	430,0	156,0	391,0	150,0	353,0	24
26	143,0	430,0	139,0	391,0	133,0	353,0	26
28	128,0	430,0	124,0	391,0	119,0	353,0	28
30	114,0	430,0	111,0	391,0	106,0	353,0	30
34	91,0	423,0	89,0	387,0	84,0	352,0	34
38	72,0	414,0	70,0	381,0	66,0	346,0	38
42	56,5	406,0	54,5	374,0	51,0	340,0	42
46	43,2	393,0	41,7	367,0	38,1	334,0	46
50	29,7	375,0	30,4	350,0	26,9	321,0	50
54	-	356,0	-	333,0	-	304,0	54
58	-	338,0	-	313,0	-	287,0	58
62	-	320,0	-	296,0	-	270,0	62
66	-	301,0	-	278,0	-	253,0	66
70	-	277,0	-	261,0	-	235,0	70
74	-	256,0	-	244,0	-	216,0	74
78	-	236,0	-	227,0	-	198,0	78
82	-	220,0	-	210,0	-	182,0	82
86	-	203,0	-	195,0	-	163,0	86
90	-	187,0	-	186,0	-	143,0	90
94	-	173,0	-	174,0	-	124,0	94
98	-	159,0	-	161,0	-	106,0	98
102	-	146,0	-	148,0	-	94,0	102
106	-	134,0	-	137,0	-	87,5	106
110	-	122,0	-	125,0	-	81,5	110
114	-	111,0	-	115,0	-	75,0	114
118	-	100,0	-	104,0	-	69,0	118
122	-	90,0	-	94,5	-	62,5	122
126	-	82,5	-	85,0	-	56,5	126
130	-	-	-	77,0	-	50,0	130
134	-	-	-	-	-	44,1	134
138	-	-	-	-	-	37,8	138
142	-	-	-	-	-	-	142

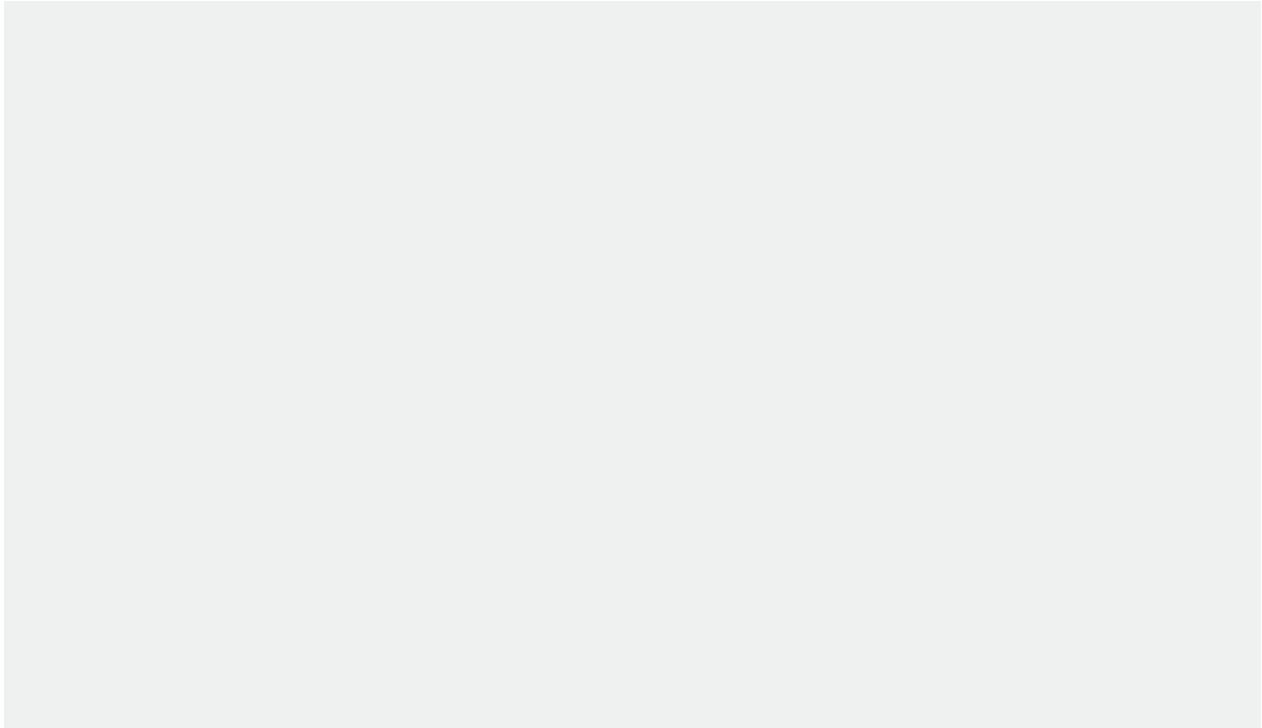



SSL / LSL + LF WORKING RANGES · ARBEITSBEREICHE · PORTÉES

20°

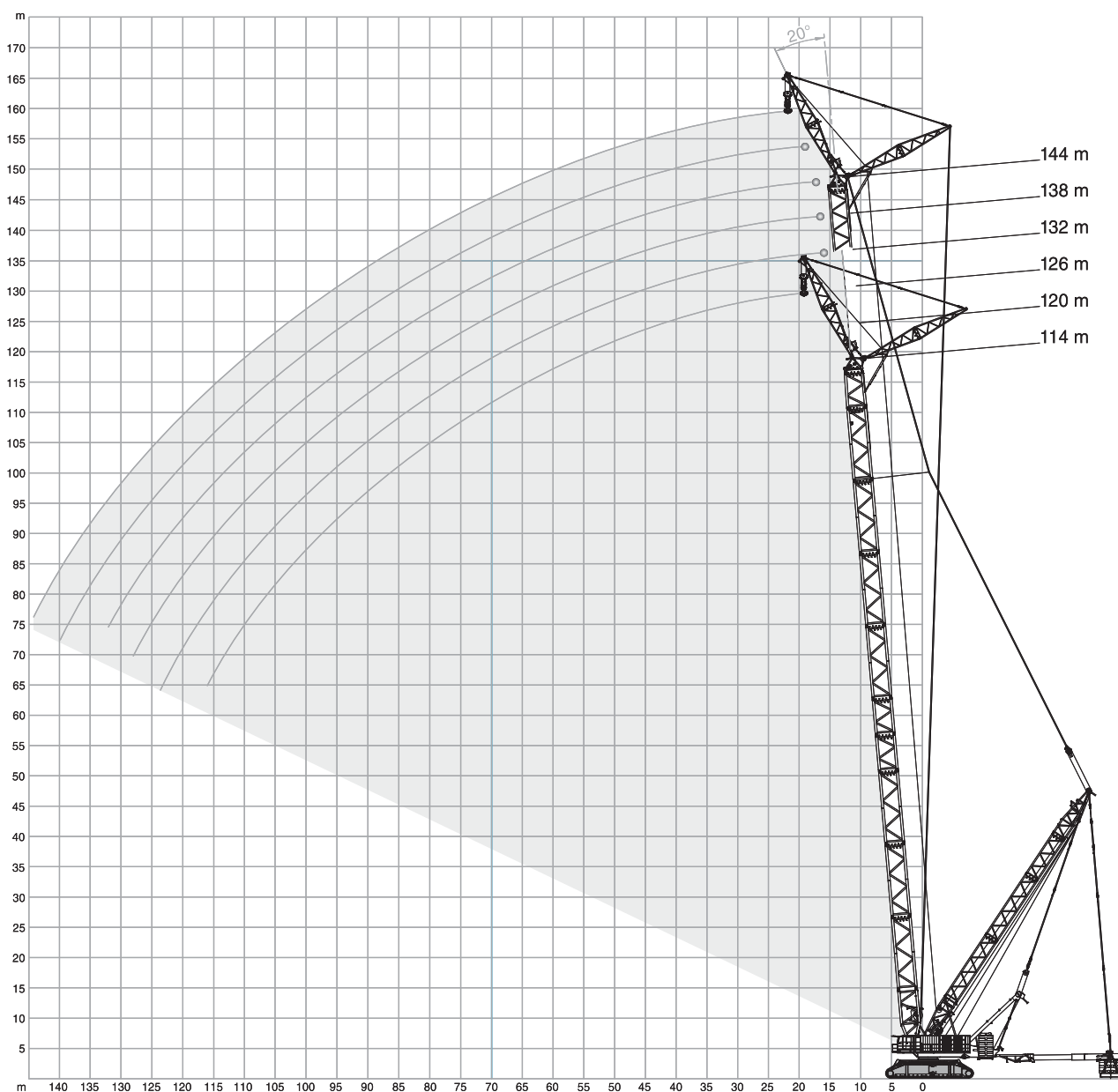



SSL / LSL + LF

235 t + 0 t ZB 19-30 m 18 m 20° 10,50 m 360° ISO

m	114 m		120 m		126 m		132 m		138 m		144 m		m
	0 t	0t-640t	0 t	0t-640t	0 t	0t-640t	0 t	0t-640t	0 t	0t-640t	0 t	0t-640t	
22	177,0	400,0	170,0	400,0	160,0	400,0	153,0	380,0	-	-	-	-	22
24	157,0	400,0	151,0	400,0	141,0	400,0	134,0	380,0	128,0	360,0	122,0	322,0	24
26	140,0	400,0	134,0	400,0	125,0	400,0	119,0	380,0	112,0	360,0	106,0	322,0	26
28	125,0	400,0	119,0	400,0	111,0	400,0	105,0	380,0	98,5	360,0	93,5	321,0	28
30	112,2	400,0	106,7	400,0	98,7	400,0	93,0	380,0	87,0	360,0	82,0	320,5	30
34	89,2	400,0	84,5	400,0	76,7	400,0	71,2	380,0	66,0	360,0	61,2	319,5	34
38	70,5	400,0	66,2	400,0	58,7	400,0	53,5	376,0	48,6	360,0	44,2	318,0	38
42	55,1	400,0	51,1	400,0	43,7	397,0	38,8	365,0	34,0	356,0	29,9	315,0	42
44	48,2	400,0	44,2	400,0	36,9	394,0	32,1	360,0	27,3	352,0	23,3	313,0	44
46	42,1	400,0	38,2	400,0	31,0	391,0	26,3	354,5	-	348,0	-	311,0	46
48	36,1	400,0	32,3	400,0	25,2	388,0	20,5	349,0	-	344,0	-	309,0	48
50	30,9	387,0	27,2	385,5	-	376,5	-	332,0	-	327,5	-	306,5	50
52	25,7	374,0	22,1	371,0	-	365,0	-	317,0	-	322,0	-	304,0	52
54	-	356,5	-	353,5	-	347,5	-	305,5	-	310,5	-	293,0	54
58	-	323,5	-	320,5	-	314,5	-	282,5	-	288,0	-	275,5	58
62	-	295,0	-	292,0	-	286,0	-	259,5	-	266,0	-	256,5	62
66	-	270,0	-	267,5	-	261,0	-	237,0	-	244,0	-	237,0	66
70	-	248,0	-	245,5	-	239,0	-	214,5	-	221,5	-	217,5	70
74	-	228,5	-	225,5	-	219,5	-	191,5	-	199,0	-	198,0	74
78	-	211,0	-	208,0	-	202,0	-	169,0	-	177,0	-	178,5	78
82	-	195,5	-	192,5	-	186,5	-	149,5	-	155,0	-	159,0	82
86	-	181,0	-	178,0	-	172,0	-	129,0	-	134,5	-	140,5	86
90	-	168,0	-	165,0	-	159,0	-	115,0	-	117,5	-	121,0	90
94	-	156,5	-	153,5	-	147,0	-	109,0	-	105,0	-	107,5	94
98	-	145,5	-	142,5	-	136,0	-	103,5	-	99,2	-	97,5	98
102	-	135,5	-	132,5	-	126,0	-	98,2	-	93,7	-	92,2	102
106	-	126,5	-	123,5	-	117,0	-	92,5	-	88,2	-	86,7	106
110	-	118,0	-	115,0	-	109,0	-	86,7	-	82,7	-	81,2	110
114	-	110,5	-	107,5	-	101,2	-	81,2	-	77,2	-	75,7	114
116	-	107,0	-	104,0	-	97,5	-	78,5	-	74,5	-	73,0	116
118	-	-	-	100,5	-	94,0	-	75,5	-	71,7	-	70,2	118
122	-	-	-	91,7	-	87,2	-	69,7	-	66,2	-	64,5	122
124	-	-	-	86,5	-	84,0	-	67,0	-	63,5	-	61,5	124
126	-	-	-	-	-	79,5	-	64,2	-	60,7	-	58,7	126
128	-	-	-	-	-	75,0	-	61,5	-	58,0	-	56,0	128
130	-	-	-	-	-	-	-	58,5	-	55,2	-	53,2	130
132	-	-	-	-	-	-	-	55,5	-	52,5	-	50,5	132
134	-	-	-	-	-	-	-	-	-	49,8	-	47,9	134
138	-	-	-	-	-	-	-	-	-	44,3	-	42,6	138
140	-	-	-	-	-	-	-	-	-	41,6	-	39,8	140
142	-	-	-	-	-	-	-	-	-	-	-	37,0	142
144	-	-	-	-	-	-	-	-	-	-	-	34,3	144
148	-	-	-	-	-	-	-	-	-	-	-	-	148

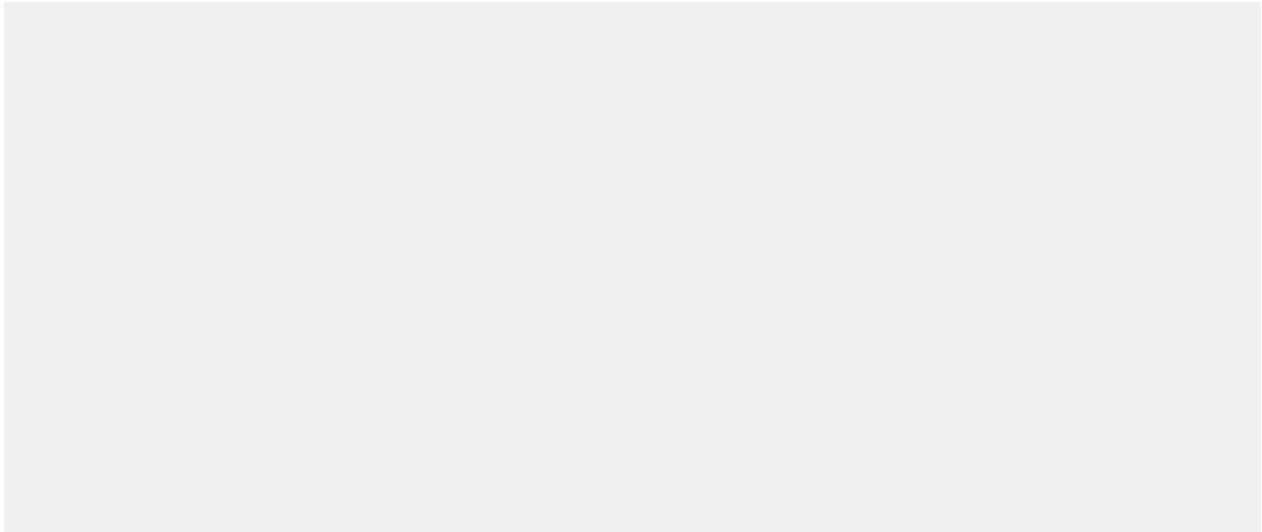



SWSL WORKING RANGES · ARBEITSBEREICHE · PORTÉES

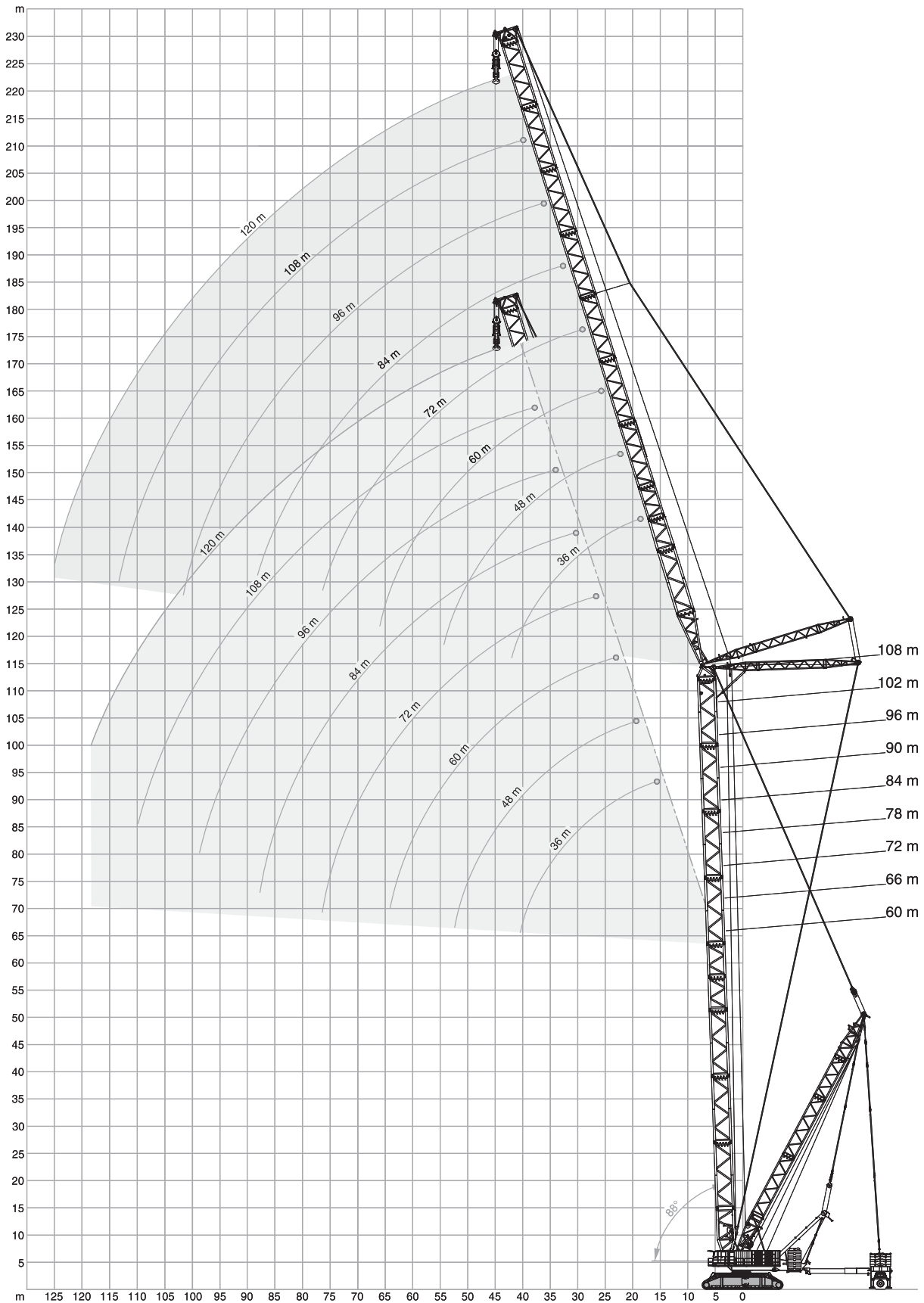



SWSL / SFSL 15° LIFTING CAPACITIES · TRAGFÄHIGKEITEN · CAPACITÉS DE LEVAGE

295 t + 60 t ZB 19-30 m 10,50 m 360° ISO

60 m + 36 m

m	SWSL					SFSL
	0 t		0 t-800 t			t
	85°	85°	75°	65°	55°	
18	-	793,0*	-	-	-	-
20	-	783,0*	-	-	-	-
22	-	764,0*	-	-	-	-
24	276,0	800,0	-	-	-	785,0
26	254,0	730,0	-	-	-	783,0
28	235,0	647,0	-	-	-	779,0
30	219,0	580,0	-	-	-	745,0
34	190,0	479,0	-	-	-	678,0
38	162,0	405,0	-	-	-	622,0
39	156,0	390,5	625,0	-	-	609,0
42	140,0	350,0	535,0	-	-	566,5
46	-	-	447,0	-	-	507,0
50	-	-	382,0	-	-	449,0
52	-	-	355,0	-	-	421,0
54	-	-	-	421,0	-	396,5
58	-	-	-	386,0	-	351,0
62	-	-	-	354,0	-	312,5
63	-	-	-	343,0	-	303,7
66	-	-	-	-	-	278,0
67	-	-	-	-	288,0	269,5
70	-	-	-	-	273,0	248,5
72	-	-	-	-	263,0	238,0
74	-	-	-	-	-	226,0
78	-	-	-	-	-	201,0
82	-	-	-	-	-	176,0
86	-	-	-	-	-	152,5
88	-	-	-	-	-	141,0

60 m + 48 m

m	t	t	t	t	t	t
22	-	629,0*	-	-	-	-
24	-	623,0*	-	-	-	-
26	-	610,0*	-	-	-	-
28	219,0	661,0	-	-	-	649,0
30	203,0	621,0	-	-	-	640,0
34	177,0	512,0	-	-	-	609,0
38	156,0	433,0	-	-	-	556,0
42	134,0	373,0	-	-	-	512,0
45	120,5	337,0	498,0	-	-	481,7
46	116,0	326,0	477,0	-	-	472,5
50	102,0	289,0	407,0	-	-	438,0
54	90,5	240,0	353,0	-	-	404,0
58	-	-	310,0	-	-	365,0
62	-	-	276,0	347,0	-	325,0
64	-	-	262,0	333,0	-	306,0
66	-	-	-	321,0	-	290,0
70	-	-	-	292,0	-	260,5
74	-	-	-	261,0	-	233,5
75	-	-	-	255,0	-	226,7
76	-	-	-	-	236,0	220,0
78	-	-	-	-	229,0	210,0
82	-	-	-	-	216,0	193,0
84	-	-	-	-	210,0	184,0
86	-	-	-	-	-	173,5
90	-	-	-	-	-	153,0
94	-	-	-	-	-	133,5
98	-	-	-	-	-	114,5
100	-	-	-	-	-	105,0
102	-	-	-	-	-	-

60 m + 60 m

m	SWSL					SFSL
	0 t		0 t-800 t			t
	85°	85°	75°	65°	55°	
26	-	504,0*	-	-	-	-
28	-	500,0*	-	-	-	-
30	-	492,0*	-	-	-	-
32	177,0	532,0	-	-	-	522,0
34	166,0	528,0	-	-	-	516,0
38	145,0	449,0	-	-	-	507,0
42	129,0	387,0	-	-	-	467,5
46	113,0	338,0	-	-	-	431,0
50	99,0	299,0	-	-	-	398,5
52	93,0	282,0	392,0	-	-	383,0
54	87,0	266,0	366,0	-	-	369,5
58	76,5	237,0	321,0	-	-	344,0
62	67,5	205,0	285,0	-	-	322,5
66	60,5	172,0	255,0	-	-	300,0
69	-	-	236,0	298,0	-	279,7
70	-	-	230,0	293,0	-	272,5
74	-	-	205,0	269,0	-	245,5
76	-	-	189,0	255,0	-	233,0
78	-	-	-	242,0	-	221,0
82	-	-	-	218,0	-	199,0
86	-	-	-	199,0	197,0	180,5
90	-	-	-	-	186,0	166,5
94	-	-	-	-	177,0	151,0
95	-	-	-	-	175,0	146,5
98	-	-	-	-	-	133,5
102	-	-	-	-	-	117,5
106	-	-	-	-	-	102,5
108	-	-	-	-	-	95,0

60 m + 72 m

m	t	t	t	t	t	t
30	-	407,0*	-	-	-	-
34	-	399,0*	-	-	-	-
36	144,0	426,0	-	-	-	417,0
38	135,0	426,0	-	-	-	416,0
42	119,0	388,0	-	-	-	411,5
46	106,0	338,0	-	-	-	393,5
50	94,5	298,0	-	-	-	362,5
54	84,0	265,0	-	-	-	335,5
58	73,0	237,0	321,0	-	-	311,5
62	64,0	214,0	284,0	-	-	290,5
66	56,0	193,0	253,0	-	-	272,0
70	49,0	170,0	228,0	-	-	255,5
74	43,5	148,0	206,0	-	-	241,5
76	41,0	137,0	196,0	-	-	235,0
77	-	-	191,5	246,0	-	231,2
78	-	-	187,0	239,0	-	227,5
82	-	-	171,0	216,0	-	209,0
86	-	-	150,0	196,0	-	188,5
90	-	-	-	179,0	-	171,0
94	-	-	-	163,0	-	156,0
95	-	-	-	160,0	168,0	153,0
96	-	-	-	157,0	165,0	150,0
98	-	-	-	-	161,0	144,0
102	-	-	-	-	153,0	130,5
106	-	-	-	-	146,0	116,0
110	-	-	-	-	-	102,5
114	-	-	-	-	-	89,7
118	-	-	-	-	-	77,2
120	-	-	-	-	-	71,0

Remarks · Bemerkungen · Remarques:

* Main boom angle 88° · Hauptauslegerwinkel 88° · Jarret de fleche principale 88°

see page 20 · siehe Seite 20 · voir page 20

4





SWSL / SFSL 15° LIFTING CAPACITIES · TRAGFÄHIGKEITEN · CAPACITÉS DE LEVAGE

295 t + 60 t ZB 19-30 m 10,50 m 360° ISO

60 m + 84 m

m	SWSL					SFSL
	0 t		0 t-800 t			
	85°	85°	75°	65°	55°	t
32	-	325,0*	-	-	-	-
34	-	325,0*	-	-	-	-
38	-	317,0*	-	-	-	-
40	117,0	331,0	-	-	-	325,0
42	110,0	331,0	-	-	-	323,5
46	97,0	326,0	-	-	-	321,0
50	86,0	298,0	-	-	-	319,0
54	76,5	265,0	-	-	-	308,0
58	68,0	237,0	-	-	-	288,0
62	60,5	213,0	-	-	-	268,0
64	57,0	203,0	268,0	-	-	258,0
66	53,0	193,0	253,0	-	-	249,5
70	46,0	175,0	227,0	-	-	233,0
74	40,0	160,0	205,0	-	-	218,5
78	34,5	145,0	186,0	-	-	206,0
82	30,2	128,0	169,0	-	-	195,0
86	26,0	112,0	155,0	195,0	-	184,5
88	24,0	104,0	148,0	185,0	-	179,0
90	-	-	142,0	177,0	-	174,5
94	-	-	131,0	162,0	-	162,0
98	-	-	115,0	148,0	-	147,5
102	-	-	-	136,0	-	135,0
104	-	-	-	131,0	143,0	130,0
106	-	-	-	125,0	140,0	125,0
108	-	-	-	120,0	136,0	120,0
110	-	-	-	-	133,0	113,5
114	-	-	-	-	126,0	101,5
118	-	-	-	-	119,0	90,0
122	-	-	-	-	-	78,5
126	-	-	-	-	-	67,5
130	-	-	-	-	-	56,5
132	-	-	-	-	-	51,0
134	-	-	-	-	-	-
138	-	-	-	-	-	-
142	-	-	-	-	-	-

60 m + 96 m

m	SWSL					SFSL
	0 t		0 t-800 t			
	85°	85°	75°	65°	55°	t
36	-	254,0*	-	-	-	-
38	-	254,0*	-	-	-	-
42	-	248,0*	-	-	-	-
44	95,5	257,0	-	-	-	251,0
46	89,5	257,0	-	-	-	249,5
50	79,0	250,0	-	-	-	246,0
54	69,5	243,0	-	-	-	242,0
58	61,5	235,0	-	-	-	237,5
62	54,5	212,0	-	-	-	232,0
66	48,0	192,0	-	-	-	226,0
70	42,5	174,0	226,0	-	-	216,0
74	37,0	158,0	203,0	-	-	202,0
78	31,5	145,0	184,0	-	-	189,0
82	26,7	133,0	168,0	-	-	177,5
86	22,5	121,5	153,0	-	-	167,5
88	20,5	116,0	146,0	-	-	163,0
90	-	109,5	140,0	-	-	158,5
94	-	97,0	128,0	160,0	-	150,0
98	-	84,7	118,0	146,0	-	142,5
100	-	78,5	113,0	140,0	-	139,0
102	-	-	109,0	134,0	-	135,0
106	-	-	100,0	123,0	-	126,5
110	-	-	88,0	113,0	-	117,5
113	-	-	-	107,0	123,0	110,7
114	-	-	-	105,0	121,0	108,5
118	-	-	-	97,0	115,0	98,5
120	-	-	-	93,0	111,0	93,0
122	-	-	-	-	107,0	88,0
126	-	-	-	-	99,0	77,7
128	-	-	-	-	95,5	72,5
130	-	-	-	-	-	67,7
134	-	-	-	-	-	58,0
138	-	-	-	-	-	48,5
142	-	-	-	-	-	39,2
144	-	-	-	-	-	34,5

Remarks · Bemerkungen · Remarques

Main boom angle 88°, 85°, 75°, 65° and 55°; capacities for intermediate boom positions are calculated by the crane control system IC-1
 Hauptauslegerwinkel 88°, 85°, 75°, 65° und 55°; Traglasten für Zwischenstellungen des Hauptauslegers werden von der Kransteuerung IC-1 berechnet
 Jarret de flèche principale 88°, 85°, 75°, 65° et 55°; le système de commande de la grue IC-1 calcule les charges pour les positions intermédiaires de la flèche
 * Main boom angle 88° · Hauptauslegerwinkel 88° · Jarret de flèche principale 88°





SWSL / SFSL 15° LIFTING CAPACITIES · TRAGFÄHIGKEITEN · CAPACITÉS DE LEVAGE

295 t + 60 t ZB 19-30 m 10,50 m 360° ISO

60 m + 108 m

60 m + 120 m

m	SWSL					SFSL
	0 t		0 t-800 t			
	85°	85°	75°	65°	55°	t
40	-	193,0*	-	-	-	-
42	-	193,0*	-	-	-	-
46	-	188,0*	-	-	-	-
48	76,5	192,0	-	-	-	189,0
50	71,5	192,0	-	-	-	188,0
54	63,0	188,0	-	-	-	185,0
58	55,0	183,0	-	-	-	182,0
62	48,0	178,0	-	-	-	179,0
66	42,0	173,0	-	-	-	175,0
70	36,5	167,0	-	-	-	170,5
74	31,5	157,0	-	-	-	165,5
76	29,0	150,0	169,0	-	-	163,0
78	27,0	143,0	169,0	-	-	160,5
82	22,7	131,0	166,0	-	-	156,0
84	21,0	125,0	158,0	-	-	154,0
86	-	120,0	151,0	-	-	152,0
90	-	110,5	138,0	-	-	146,0
94	-	101,7	126,0	-	-	137,5
98	-	92,7	116,0	-	-	129,5
100	-	88,0	111,0	138,0	-	126,0
102	-	83,0	107,0	132,0	-	123,0
106	-	73,0	98,5	121,0	-	116,5
108	-	68,0	94,5	116,0	-	113,0
110	-	-	90,5	111,0	-	110,0
114	-	-	83,5	102,0	-	104,0
118	-	-	76,0	94,5	-	99,0
122	-	-	66,5	87,0	98,0	93,2
126	-	-	-	80,5	96,5	84,7
130	-	-	-	74,0	89,0	75,5
132	-	-	-	71,5	85,5	71,0
134	-	-	-	-	82,5	66,5
138	-	-	-	-	76,0	57,5
140	-	-	-	-	73,0	53,0
142	-	-	-	-	-	48,7
146	-	-	-	-	-	40,5
150	-	-	-	-	-	32,2
154	-	-	-	-	-	24,0
156	-	-	-	-	-	20,0
158	-	-	-	-	-	-

m	SWSL					SFSL
	0 t		0 t-800 t			
	85°	85°	75°	65°	55°	t
44	-	146,0*	-	-	-	-
46	-	145,0*	-	-	-	-
50	-	142,0*	-	-	-	-
52	60,0	143,0	-	-	-	140,0
54	56,0	143,0	-	-	-	139,5
58	48,5	141,0	-	-	-	138,0
62	41,5	138,0	-	-	-	135,5
66	35,5	134,0	-	-	-	132,5
70	30,5	130,0	-	-	-	129,0
74	25,5	124,0	-	-	-	125,5
78	21,0	118,0	-	-	-	122,0
82	-	111,0	116,0	-	-	117,5
86	-	104,5	115,0	-	-	113,0
90	-	98,0	109,0	-	-	108,5
94	-	92,0	102,0	-	-	104,5
98	-	86,2	96,5	-	-	101,0
102	-	80,7	90,5	-	-	97,0
106	-	74,7	84,5	-	-	92,7
108	-	71,5	81,0	88,5	-	90,5
110	-	67,5	78,0	88,5	-	88,7
114	-	59,5	72,5	84,5	-	84,7
118	-	51,7	68,0	79,5	-	80,5
120	-	48,0	65,5	77,0	-	78,5
122	-	-	63,0	74,5	-	76,7
126	-	-	58,2	69,5	-	73,5
130	-	-	53,5	64,5	-	70,2
132	-	-	51,0	62,0	67,5	68,5
134	-	-	-	60,0	67,5	66,2
138	-	-	-	56,0	65,5	61,0
142	-	-	-	52,0	61,0	53,7
146	-	-	-	-	56,5	46,0
150	-	-	-	-	53,0	38,5
152	-	-	-	-	51,0	35,0
154	-	-	-	-	-	31,2
158	-	-	-	-	-	24,0
160	-	-	-	-	-	20,5
162	-	-	-	-	-	-
166	-	-	-	-	-	-
170	-	-	-	-	-	-

Remarks · Bemerkungen · Remarques

Main boom angle 88°, 85°, 75°, 65° and 55°; capacities for intermediate boom positions are calculated by the crane control system IC-1
 Hauptauslegerwinkel 88°, 85°, 75°, 65° und 55°; Traglasten für Zwischenstellungen des Hauptauslegers werden von der Kransteuerung IC-1 berechnet
 Jarret de flèche principale 88°, 85°, 75°, 65° et 55°; le système de commande de la grue IC-1 calcule les charges pour les positions intermédiaires de la flèche
 * Main boom angle 88° · Hauptauslegerwinkel 88° · Jarret de flèche principale 88°





SWSL / SFSL 15° LIFTING CAPACITIES · TRAGFÄHIGKEITEN · CAPACITÉS DE LEVAGE

295 t + 60 t ZB 19-30 m 10,50 m 360° ISO

66 m + 36 m

m	SWSL					SFSL
	0 t		0 t-800 t			
	85°	85°	75°	65°	55°	t
18	-	733,0*	-	-	-	-
20	-	721,0*	-	-	-	-
22	-	702,0*	-	-	-	-
24	265,0	771,0	-	-	-	758,0
26	244,0	753,0	-	-	-	747,0
28	226,0	666,0	-	-	-	733,0
30	210,0	595,0	-	-	-	725,0
34	184,0	489,0	-	-	-	696,0
38	159,0	413,0	-	-	-	640,0
41	142,0	369,0	590,0	-	-	585,0
42	137,0	356,0	577,0	-	-	568,0
46	-	-	476,0	-	-	505,0
50	-	-	404,0	-	-	452,0
54	-	-	349,0	-	-	406,0
57	-	-	-	398,0	-	373,2
58	-	-	-	390,0	-	362,5
62	-	-	-	360,0	-	322,5
66	-	-	-	334,0	-	288,5
70	-	-	-	-	-	258,0
71	-	-	-	-	270,0	250,5
74	-	-	-	-	256,0	229,0
76	-	-	-	-	248,0	215,0
78	-	-	-	-	-	204,5
82	-	-	-	-	-	186,5
86	-	-	-	-	-	166,0
90	-	-	-	-	-	144,5
92	-	-	-	-	-	134,0

66 m + 48 m

m	t	t	t	t	t	t
22	-	586,0*	-	-	-	-
24	-	579,0*	-	-	-	-
26	-	567,0*	-	-	-	-
28	210,0	622,0	-	-	-	610,0
30	195,0	616,0	-	-	-	604,0
34	170,0	523,0	-	-	-	588,0
38	150,0	440,0	-	-	-	569,0
42	131,0	379,0	-	-	-	524,5
46	114,0	330,0	-	-	-	485,5
47	110,0	320,0	487,0	-	-	476,2
50	100,0	292,0	431,0	-	-	449,5
54	88,5	248,0	371,0	-	-	411,5
58	-	-	325,0	-	-	372,0
62	-	-	287,0	-	-	334,5
64	-	-	272,0	331,0	-	316,0
66	-	-	257,0	324,0	-	299,5
70	-	-	-	301,0	-	268,5
74	-	-	-	279,0	-	241,5
77	-	-	-	257,0	-	223,2
78	-	-	-	-	-	217,5
80	-	-	-	-	222,0	206,0
82	-	-	-	-	215,0	194,5
86	-	-	-	-	202,0	173,5
87	-	-	-	-	199,0	169,7
90	-	-	-	-	-	159,0
94	-	-	-	-	-	143,0
98	-	-	-	-	-	125,0
102	-	-	-	-	-	107,7
104	-	-	-	-	-	99,5

Remarks · Bemerkungen · Remarques:
see page 23 · siehe Seite 23 · voir page 23

66 m + 60 m

m	SWSL					SFSL
	0 t		0 t-800 t			
	85°	85°	75°	65°	55°	t
26	-	474,0*	-	-	-	-
28	-	470,0*	-	-	-	-
30	-	462,0*	-	-	-	-
32	170,0	501,0	-	-	-	491,0
34	159,0	501,0	-	-	-	490,0
38	139,0	458,0	-	-	-	480,0
42	123,0	393,0	-	-	-	467,0
46	110,0	343,0	-	-	-	440,0
50	97,0	302,0	-	-	-	408,0
54	85,0	269,0	385,0	-	-	380,0
58	74,5	242,0	336,0	-	-	355,0
62	65,5	210,0	297,0	-	-	332,5
66	58,0	178,0	265,0	-	-	309,0
70	-	-	239,0	-	-	281,0
72	-	-	227,0	285,0	-	266,0
74	-	-	216,0	275,0	-	253,0
78	-	-	186,0	257,0	-	228,0
82	-	-	-	233,0	-	206,5
86	-	-	-	211,0	-	187,0
88	-	-	-	202,0	-	177,0
89	-	-	-	-	186,0	172,2
90	-	-	-	-	183,0	167,5
94	-	-	-	-	173,0	149,5
98	-	-	-	-	164,0	138,0
102	-	-	-	-	-	125,0
106	-	-	-	-	-	110,0
110	-	-	-	-	-	96,0
114	-	-	-	-	-	82,0
116	-	-	-	-	-	75,0

66 m + 72 m

m	t	t	t	t	t	t
30	-	384,0*	-	-	-	-
34	-	376,0*	-	-	-	-
36	137,0	403,0	-	-	-	395,0
38	129,0	403,0	-	-	-	394,0
42	114,0	395,0	-	-	-	390,0
46	101,0	346,0	-	-	-	388,0
50	90,0	304,0	-	-	-	373,5
54	80,5	270,0	-	-	-	347,5
58	71,0	242,0	-	-	-	323,5
60	66,5	230,0	318,0	-	-	312,0
62	62,0	218,0	299,0	-	-	302,0
66	54,0	197,0	266,0	-	-	282,5
70	47,5	174,0	239,0	-	-	265,0
74	41,5	151,0	215,0	-	-	250,5
78	37,0	129,0	195,0	-	-	235,5
80	-	-	186,0	243,0	-	227,0
82	-	-	178,0	232,0	-	216,0
86	-	-	159,0	210,0	-	195,5
88	-	-	148,0	200,0	-	186,0
90	-	-	-	190,0	-	176,5
94	-	-	-	174,0	-	159,5
98	-	-	-	159,0	157,0	144,5
100	-	-	-	152,0	152,0	137,0
102	-	-	-	-	148,0	129,0
106	-	-	-	-	140,0	119,5
110	-	-	-	-	133,0	108,5
114	-	-	-	-	-	96,0
118	-	-	-	-	-	84,0
122	-	-	-	-	-	72,0
124	-	-	-	-	-	66,0





SWSL / SFSL 15° LIFTING CAPACITIES · TRAGFÄHIGKEITEN · CAPACITÉS DE LEVAGE

295 t + 60 t ZB 19-30 m 10,50 m 360° ISO

66 m + 84 m

66 m + 96 m

m	SWSL					SFSL
	0 t		0 t-800 t			
	85°	85°	75°	65°	55°	t
34	-	310,0*	-	-	-	-
38	-	302,0*	-	-	-	-
40	111,0	316,0	-	-	-	310,0
42	104,0	316,0	-	-	-	309,5
46	92,0	312,0	-	-	-	308,5
50	81,5	305,0	-	-	-	307,0
54	72,5	271,0	-	-	-	304,0
58	64,5	242,0	-	-	-	294,5
62	57,0	218,0	-	-	-	277,0
66	51,0	197,0	266,0	-	-	258,5
70	44,5	179,0	238,0	-	-	242,5
74	38,5	163,0	215,0	-	-	227,5
78	33,0	147,0	194,0	-	-	214,0
82	28,5	131,0	177,0	-	-	202,5
86	24,5	114,5	161,0	-	-	191,5
88	22,5	106,0	154,0	199,0	-	186,0
90	-	-	148,0	189,0	-	181,0
94	-	-	136,0	172,0	-	168,0
98	-	-	121,0	158,0	-	152,0
100	-	-	113,0	151,0	-	144,0
102	-	-	-	145,0	-	138,0
106	-	-	-	133,0	-	125,0
107	-	-	-	130,5	133,0	121,5
110	-	-	-	123,0	127,0	111,5
114	-	-	-	-	120,0	102,7
118	-	-	-	-	114,0	93,7
120	-	-	-	-	111,0	89,0
122	-	-	-	-	-	83,5
126	-	-	-	-	-	72,7
130	-	-	-	-	-	62,5
134	-	-	-	-	-	52,0
136	-	-	-	-	-	46,5
138	-	-	-	-	-	-

m	SWSL					SFSL
	0 t		0 t-800 t			
	85°	85°	75°	65°	55°	t
36	-	244,0*	-	-	-	-
38	-	244,0*	-	-	-	-
42	-	238,0*	-	-	-	-
44	90,0	246,0	-	-	-	242,0
46	84,5	246,0	-	-	-	240,5
50	74,5	242,0	-	-	-	237,5
54	65,5	236,0	-	-	-	234,5
58	58,0	228,0	-	-	-	231,0
62	51,0	217,0	-	-	-	226,0
66	45,0	196,0	-	-	-	220,5
70	39,5	177,0	-	-	-	215,0
72	37,0	169,0	223,0	-	-	212,0
74	34,5	162,0	213,0	-	-	207,0
78	30,0	148,0	193,0	-	-	196,0
82	25,2	135,5	175,0	-	-	184,5
84	23,0	130,0	167,0	-	-	179,0
86	-	124,0	160,0	-	-	174,0
90	-	111,5	146,0	-	-	165,0
94	-	99,0	134,0	-	-	156,5
96	-	93,0	128,0	163,0	-	152,0
98	-	86,7	123,0	156,0	-	148,0
100	-	80,5	118,0	149,0	-	144,0
102	-	-	113,0	143,0	-	141,0
106	-	-	104,0	131,0	-	131,0
110	-	-	93,0	120,0	-	119,0
112	-	-	87,0	115,0	-	114,0
114	-	-	-	111,0	-	107,5
117	-	-	-	104,0	110,0	98,5
118	-	-	-	102,0	109,0	96,0
122	-	-	-	95,0	103,0	88,5
126	-	-	-	-	98,5	80,7
130	-	-	-	-	94,0	71,7
132	-	-	-	-	92,0	67,0
134	-	-	-	-	-	62,5
138	-	-	-	-	-	53,2
142	-	-	-	-	-	44,0
146	-	-	-	-	-	35,2
148	-	-	-	-	-	31,0
150	-	-	-	-	-	-

Remarks · Bemerkungen · Remarques

Main boom angle 88°, 85°, 75°, 65° and 55°; capacities for intermediate boom positions are calculated by the crane control system IC-1

Hauptauslegerwinkel 88°, 85°, 75°, 65° und 55°; Traglasten für Zwischenstellungen des Hauptauslegers werden von der Kransteuerung IC-1 berechnet

Jarret de fleche principale 88°, 85°, 75°, 65° et 55°; le systeme de commande de la grue IC-1 calcule les charges pour les positions intermediaires de la fleche

* Main boom angle 88° · Hauptauslegerwinkel 88° · Jarret de fleche principale 88°





SWSL / SFSL 15° LIFTING CAPACITIES · TRAGFÄHIGKEITEN · CAPACITÉS DE LEVAGE

295 t + 60 t ZB 19-30 m 10,50 m 360° ISO

66 m + 108 m

m	SWSL					SFSL
	0 t		0 t-800 t			
	85°	85°	75°	65°	55°	t
40	-	187,0*	-	-	-	-
42	-	187,0*	-	-	-	-
46	-	182,0*	-	-	-	-
48	72,0	185,0	-	-	-	182,0
50	67,5	185,0	-	-	-	182,0
54	58,5	182,0	-	-	-	180,5
58	51,5	178,0	-	-	-	177,5
62	44,5	173,0	-	-	-	174,5
66	38,5	168,0	-	-	-	170,5
70	33,5	163,0	-	-	-	166,0
74	28,5	158,0	-	-	-	162,0
78	24,0	146,0	165,0	-	-	158,0
80	22,0	140,0	165,0	-	-	156,0
82	-	134,0	164,0	-	-	153,5
86	-	122,5	158,0	-	-	149,0
90	-	112,5	144,0	-	-	145,5
94	-	103,7	132,0	-	-	141,5
98	-	94,5	121,0	-	-	135,5
102	-	84,5	111,0	-	-	128,5
104	-	79,5	107,0	135,0	-	125,0
106	-	74,7	102,0	129,0	-	121,5
110	-	65,0	94,5	118,0	-	115,5
112	-	60,0	90,5	113,0	-	113,0
114	-	-	87,0	109,0	-	110,0
118	-	-	80,0	100,0	-	102,2
122	-	-	70,5	92,5	-	92,5
126	-	-	-	85,5	93,0	82,7
130	-	-	-	79,0	89,0	76,0
134	-	-	-	73,0	84,5	69,0
138	-	-	-	-	80,5	61,2
142	-	-	-	-	76,0	52,7
144	-	-	-	-	73,0	48,5
146	-	-	-	-	-	44,5
150	-	-	-	-	-	36,5
154	-	-	-	-	-	28,5
156	-	-	-	-	-	24,5
158	-	-	-	-	-	-

66 m + 120 m

m	SWSL					SFSL
	0 t		0 t-800 t			
	85°	85°	75°	65°	55°	t
44	-	141,0*	-	-	-	-
46	-	141,0*	-	-	-	-
50	-	138,0*	-	-	-	-
52	55,5	135,0	-	-	-	136,0
54	52,0	135,0	-	-	-	135,5
58	44,5	132,0	-	-	-	134,0
62	38,0	129,0	-	-	-	131,5
66	32,5	126,0	-	-	-	128,5
70	27,0	122,0	-	-	-	126,0
74	22,5	116,0	-	-	-	123,0
76	20,5	113,0	-	-	-	121,0
78	-	110,0	-	-	-	119,0
82	-	104,0	-	-	-	116,0
84	-	101,0	115,0	-	-	115,0
86	-	97,7	115,0	-	-	112,5
90	-	91,2	109,0	-	-	108,0
94	-	85,2	103,0	-	-	103,5
98	-	80,0	98,0	-	-	99,5
102	-	75,0	92,0	-	-	96,5
106	-	70,0	86,0	-	-	93,0
110	-	65,0	80,0	86,5	-	89,0
114	-	59,7	74,0	86,5	-	85,5
118	-	53,0	69,0	82,0	-	82,0
120	-	49,0	67,0	80,0	-	80,0
122	-	-	64,5	77,0	-	78,0
126	-	-	59,7	72,5	-	74,2
130	-	-	55,5	67,5	-	71,2
134	-	-	50,5	62,5	-	67,5
136	-	-	-	60,5	67,0	65,5
138	-	-	-	58,5	67,0	62,5
142	-	-	-	54,5	65,0	56,0
146	-	-	-	50,5	60,0	49,0
150	-	-	-	-	56,0	41,5
154	-	-	-	-	52,0	34,0
158	-	-	-	-	-	27,0
160	-	-	-	-	-	23,5
162	-	-	-	-	-	-

Remarks · Bemerkungen · Remarques

Main boom angle 88°, 85°, 75°, 65° and 55°; capacities for intermediate boom positions are calculated by the crane control system IC-1
 Hauptauslegerwinkel 88°, 85°, 75°, 65° und 55°; Traglasten für Zwischenstellungen des Hauptauslegers werden von der Kransteuerung IC-1 berechnet
 Jarret de flèche principale 88°, 85°, 75°, 65° et 55°; le système de commande de la grue IC-1 calcule les charges pour les positions intermédiaires de la flèche

* Main boom angle 88° · Hauptauslegerwinkel 88° · Jarret de flèche principale 88°





SWSL / SFSL 15° LIFTING CAPACITIES · TRAGFÄHIGKEITEN · CAPACITÉS DE LEVAGE

295 t + 60 t ZB 19-30 m 10,50 m 360° ISO

72 m + 36 m

m	SWSL					SFSL
	0 t		0 t-800 t			
	85°	85°	75°	65°	55°	t
20	-	661,0*	-	-	-	-
22	-	641,0*	-	-	-	-
24	253,0	705,0	-	-	-	692,0
26	234,0	702,0	-	-	-	688,0
28	217,0	683,0	-	-	-	677,0
30	202,0	611,0	-	-	-	671,0
34	176,0	500,0	-	-	-	664,0
38	156,0	420,0	-	-	-	621,0
42	135,0	361,0	569,0	-	-	563,5
44	125,0	337,0	563,0	-	-	529,0
46	-	-	510,0	-	-	500,5
50	-	-	428,0	-	-	447,5
54	-	-	367,0	-	-	403,0
56	-	-	342,0	-	-	383,0
58	-	-	-	-	-	365,5
59	-	-	-	381,0	-	356,7
62	-	-	-	359,0	-	329,5
66	-	-	-	332,0	-	294,5
68	-	-	-	321,0	-	278,0
70	-	-	-	-	-	264,0
74	-	-	-	-	254,0	236,0
78	-	-	-	-	238,0	210,0
79	-	-	-	-	234,0	204,0
82	-	-	-	-	-	186,5
86	-	-	-	-	-	168,0
90	-	-	-	-	-	152,0
94	-	-	-	-	-	133,5
96	-	-	-	-	-	124,0

72 m + 60 m

m	SWSL					SFSL
	0 t		0 t-800 t			
	85°	85°	75°	65°	55°	t
26	-	438,0*	-	-	-	-
28	-	434,0*	-	-	-	-
30	-	425,0*	-	-	-	-
32	162,0	464,0	-	-	-	455,0
34	151,0	464,0	-	-	-	454,0
38	133,0	452,0	-	-	-	448,0
42	118,0	400,0	-	-	-	444,5
46	105,0	348,0	-	-	-	431,5
50	94,0	306,0	-	-	-	413,0
54	82,5	272,0	394,0	-	-	389,5
58	72,0	244,0	353,0	-	-	364,0
62	63,5	214,0	311,0	-	-	338,0
66	56,0	182,0	276,0	-	-	310,0
70	-	-	248,0	-	-	283,0
74	-	-	224,0	267,0	-	257,0
78	-	-	199,0	256,0	-	232,0
82	-	-	-	240,0	-	209,5
86	-	-	-	224,0	-	189,5
90	-	-	-	204,0	-	171,0
93	-	-	-	-	173,0	157,7
94	-	-	-	-	171,0	153,5
98	-	-	-	-	161,0	137,0
102	-	-	-	-	153,0	122,0
106	-	-	-	-	-	112,5
110	-	-	-	-	-	101,2
114	-	-	-	-	-	88,0
118	-	-	-	-	-	74,7
120	-	-	-	-	-	68,0

72 m + 48 m

m	t	t	t	t	t	t
22	-	540,0*	-	-	-	-
24	-	533,0*	-	-	-	-
26	-	519,0*	-	-	-	-
28	201,0	571,0	-	-	-	562,0
30	187,0	571,0	-	-	-	560,0
34	163,0	535,0	-	-	-	547,0
38	143,0	449,0	-	-	-	540,0
42	127,0	385,0	-	-	-	518,5
46	111,0	335,0	-	-	-	491,0
48	104,0	314,0	465,0	-	-	477,0
50	97,5	296,0	457,0	-	-	453,0
54	86,0	255,0	391,0	-	-	407,5
58	-	-	340,0	-	-	368,0
62	-	-	300,0	-	-	335,0
66	-	-	267,0	-	-	304,0
67	-	-	259,5	316,0	-	296,0
68	-	-	252,0	311,0	-	288,0
70	-	-	-	300,0	-	273,5
74	-	-	-	279,0	-	245,5
78	-	-	-	262,0	-	221,0
80	-	-	-	253,0	-	210,0
82	-	-	-	-	-	199,0
83	-	-	-	-	209,0	193,5
86	-	-	-	-	200,0	178,0
90	-	-	-	-	188,0	158,5
94	-	-	-	-	-	142,0
98	-	-	-	-	-	129,5
102	-	-	-	-	-	115,5
106	-	-	-	-	-	99,7
108	-	-	-	-	-	91,5
110	-	-	-	-	-	-

72 m + 72 m

m	t	t	t	t	t	t
30	-	358,0*	-	-	-	-
34	-	349,0*	-	-	-	-
38	123,0	378,0	-	-	-	370,0
42	108,0	372,0	-	-	-	365,0
46	96,0	354,0	-	-	-	363,5
50	85,5	311,0	-	-	-	359,5
54	76,5	276,0	-	-	-	349,5
58	68,5	246,0	-	-	-	332,0
60	64,0	234,0	334,0	-	-	322,0
62	60,0	222,0	315,0	-	-	311,5
66	52,0	200,0	280,0	-	-	292,0
70	45,5	177,0	250,0	-	-	275,0
74	39,5	155,0	225,0	-	-	259,5
78	35,0	132,0	203,0	-	-	240,0
82	-	-	185,0	231,0	-	217,5
86	-	-	168,0	220,0	-	197,5
90	-	-	146,0	203,0	-	179,0
94	-	-	-	185,0	-	163,0
98	-	-	-	169,0	-	147,5
102	-	-	-	155,0	146,0	132,0
106	-	-	-	-	138,0	118,5
110	-	-	-	-	130,0	105,5
113	-	-	-	-	126,0	98,8
114	-	-	-	-	-	96,7
118	-	-	-	-	-	87,2
122	-	-	-	-	-	76,2
126	-	-	-	-	-	65,0
130	-	-	-	-	-	53,7
132	-	-	-	-	-	48,0

see page 24 · siehe Seite 24 · voir page 24

4





SWSL / SFSL 15° LIFTING CAPACITIES · TRAGFÄHIGKEITEN · CAPACITÉS DE LEVAGE

295 t + 60 t ZB 19-30 m 10,50 m 360° ISO

72 m + 84 m

72 m + 96 m

m	SWSL					SFSL
	0 t		0 t-800 t			
	85°	85°	75°	65°	55°	t
34	-	290,0*	-	-	-	-
38	-	284,0*	-	-	-	-
42	99,0	299,0	-	-	-	-
44	93,0	298,0	-	-	-	292,0
46	87,0	296,0	-	-	-	291,0
50	77,0	291,0	-	-	-	289,5
54	68,0	276,0	-	-	-	288,5
58	60,5	247,0	-	-	-	283,0
62	53,5	222,0	-	-	-	276,5
66	47,5	200,0	280,0	-	-	266,0
70	42,0	182,0	250,0	-	-	250,5
74	36,5	166,0	225,0	-	-	235,5
78	31,5	150,0	203,0	-	-	221,5
82	27,0	133,0	184,0	-	-	210,0
86	23,0	117,0	168,0	-	-	199,5
88	21,0	109,0	160,0	-	-	194,0
90	-	-	153,0	192,0	-	186,5
94	-	-	141,0	184,0	-	170,5
98	-	-	128,0	168,0	-	154,5
102	-	-	112,0	153,0	-	140,0
106	-	-	-	141,0	-	127,0
110	-	-	-	130,0	-	114,5
111	-	-	-	127,0	123,0	111,2
114	-	-	-	120,0	118,0	102,2
118	-	-	-	-	112,0	90,7
122	-	-	-	-	106,0	83,2
124	-	-	-	-	103,0	79,5
126	-	-	-	-	-	75,0
130	-	-	-	-	-	65,5
134	-	-	-	-	-	55,7
138	-	-	-	-	-	46,0
142	-	-	-	-	-	36,0
144	-	-	-	-	-	31,0

m	SWSL					SFSL
	0 t		0 t-800 t			
	85°	85°	75°	65°	55°	t
36	-	231,0*	-	-	-	-
38	-	231,0*	-	-	-	-
42	-	226,0*	-	-	-	-
46	79,5	235,0	-	-	-	-
48	74,5	234,0	-	-	-	229,0
50	70,0	231,0	-	-	-	227,5
54	61,5	226,0	-	-	-	225,0
58	54,0	220,0	-	-	-	223,0
62	47,5	213,0	-	-	-	219,5
66	41,5	199,0	-	-	-	214,5
70	36,0	181,0	-	-	-	209,5
72	33,5	172,0	214,0	-	-	207,0
74	31,5	164,0	214,0	-	-	203,5
78	27,0	150,0	202,0	-	-	196,0
82	23,0	138,0	183,0	-	-	188,5
84	21,0	132,0	174,0	-	-	185,0
86	-	126,0	166,0	-	-	180,5
90	-	113,5	152,0	-	-	171,0
94	-	101,0	139,0	-	-	162,5
98	-	88,7	128,0	166,0	-	154,5
100	-	82,5	122,0	159,0	-	150,0
102	-	-	117,0	152,0	-	144,5
106	-	-	108,0	139,0	-	132,5
110	-	-	98,0	128,0	-	120,0
112	-	-	92,0	122,0	-	114,0
114	-	-	-	117,0	-	109,0
118	-	-	-	108,0	-	98,2
120	-	-	-	104,0	104,0	92,5
122	-	-	-	100,0	101,0	87,5
124	-	-	-	96,5	98,0	82,5
126	-	-	-	-	95,5	77,5
130	-	-	-	-	90,5	70,7
134	-	-	-	-	85,5	63,7
136	-	-	-	-	83,5	60,0
138	-	-	-	-	-	55,7
142	-	-	-	-	-	47,0
146	-	-	-	-	-	38,2
150	-	-	-	-	-	30,0
152	-	-	-	-	-	26,0

Remarks · Bemerkungen · Remarques

Main boom angle 88°, 85°, 75°, 65° and 55°; capacities for intermediate boom positions are calculated by the crane control system IC-1

Hauptauslegerwinkel 88°, 85°, 75°, 65° und 55°; Traglasten für Zwischenstellungen des Hauptauslegers werden von der Kransteuerung IC-1 berechnet

Jarret de fleche principale 88°, 85°, 75°, 65° et 55°; le systeme de commande de la grue IC-1 calcule les charges pour les positions intermediaires de la fleche

* Main boom angle 88° · Hauptauslegerwinkel 88° · Jarret de fleche principale 88°





SWSL / SFSL 15° LIFTING CAPACITIES · TRAGFÄHIGKEITEN · CAPACITÉS DE LEVAGE

295 t + 60 t ZB 19-30 m 10,50 m 360° ISO

72 m + 108 m

m	SWSL					SFSL
	0 t		0 t-800 t			
	85°	85°	75°	65°	55°	t
40	-	179,0*	-	-	-	-
42	-	179,0*	-	-	-	-
46	-	174,0*	-	-	-	-
50	62,5	178,0	-	-	-	-
52	58,5	178,0	-	-	-	174,0
54	54,5	176,0	-	-	-	173,0
58	47,5	172,0	-	-	-	170,5
62	41,0	167,0	-	-	-	167,5
66	35,0	163,0	-	-	-	165,0
70	30,0	158,0	-	-	-	161,5
74	25,5	153,0	-	-	-	157,0
78	21,0	149,0	159,0	-	-	153,0
82	-	136,0	159,0	-	-	149,5
86	-	124,5	157,0	-	-	145,5
90	-	114,5	150,0	-	-	141,5
94	-	105,5	138,0	-	-	138,0
98	-	96,0	126,0	-	-	134,5
102	-	86,0	116,0	-	-	131,0
106	-	76,2	106,0	129,0	-	126,0
110	-	66,5	98,0	126,0	-	120,0
112	-	61,5	94,0	120,0	-	117,0
114	-	-	90,5	115,0	-	113,0
118	-	-	83,5	106,0	-	103,2
122	-	-	74,7	98,0	-	93,2
124	-	-	70,0	94,0	-	89,0
126	-	-	-	90,5	-	84,0
130	-	-	-	83,5	85,5	74,5
134	-	-	-	77,0	80,5	65,5
136	-	-	-	74,0	78,5	62,5
138	-	-	-	-	76,0	59,5
142	-	-	-	-	72,0	53,2
146	-	-	-	-	68,0	46,0
148	-	-	-	-	66,0	42,0
150	-	-	-	-	-	38,2
154	-	-	-	-	-	30,7
156	-	-	-	-	-	27,0
160	-	-	-	-	-	-

72 m + 120 m

m	SWSL					SFSL
	0 t		0 t-800 t			
	85°	85°	75°	65°	55°	t
44	-	132,0*	-	-	-	-
46	-	132,0*	-	-	-	-
50	-	129,0*	-	-	-	-
54	47,5	130,0	-	-	-	-
56	44,0	130,0	-	-	-	130,0
58	40,5	128,0	-	-	-	129,0
62	34,5	126,0	-	-	-	126,5
66	29,0	122,0	-	-	-	124,5
70	24,0	119,0	-	-	-	122,5
72	21,5	117,0	-	-	-	121,0
74	-	114,0	-	-	-	119,0
78	-	108,0	-	-	-	116,0
82	-	102,2	-	-	-	113,5
84	-	99,5	112,0	-	-	112,0
86	-	96,5	112,0	-	-	110,0
90	-	90,7	109,0	-	-	106,0
94	-	85,0	104,0	-	-	102,0
98	-	79,7	98,5	-	-	98,2
102	-	75,0	93,0	-	-	95,2
106	-	70,0	87,0	-	-	92,0
110	-	65,0	81,5	-	-	88,5
114	-	60,0	75,5	84,5	-	85,2
118	-	54,0	70,5	84,0	-	81,7
122	-	46,5	66,0	80,0	-	78,5
124	-	42,5	63,5	77,5	-	77,0
126	-	-	61,5	75,0	-	75,5
130	-	-	57,0	70,0	-	72,2
134	-	-	52,5	65,5	-	67,5
136	-	-	50,0	63,0	-	64,5
138	-	-	-	61,0	66,0	60,2
142	-	-	-	57,0	65,0	52,5
146	-	-	-	53,0	61,0	47,5
148	-	-	-	51,0	59,5	45,0
150	-	-	-	-	57,5	42,0
154	-	-	-	-	55,0	35,2
158	-	-	-	-	51,5	28,2
160	-	-	-	-	-	25,0

Remarks · Bemerkungen · Remarques

Main boom angle 88°, 85°, 75°, 65° and 55°; capacities for intermediate boom positions are calculated by the crane control system IC-1
 Hauptauslegerwinkel 88°, 85°, 75°, 65° und 55°; Traglasten für Zwischenstellungen des Hauptauslegers werden von der Kransteuerung IC-1 berechnet
 Jarret de flèche principale 88°, 85°, 75°, 65° et 55°; le système de commande de la grue IC-1 calcule les charges pour les positions intermédiaires de la flèche

* Main boom angle 88° · Hauptauslegerwinkel 88° · Jarret de flèche principale 88°





SWSL / SFSL 15° LIFTING CAPACITIES · TRAGFÄHIGKEITEN · CAPACITÉS DE LEVAGE

295 t + 60 t ZB 19-30 m 10,50 m 360° ISO

78 m + 36 m

m	SWSL					SFSL
	0 t		0 t-800 t			
	85°	85°	75°	65°	55°	t
20	-	611,0*	-	-	-	-
22	-	593,0*	-	-	-	-
24	-	574,0*	-	-	-	-
26	224,0	649,0	-	-	-	636,0
28	207,0	636,0	-	-	-	628,0
30	193,0	620,0	-	-	-	625,0
34	169,0	511,0	-	-	-	619,0
38	150,0	428,0	-	-	-	588,0
42	132,0	367,0	-	-	-	548,5
44	123,0	342,0	532,0	-	-	526,0
46	-	-	529,0	-	-	497,0
50	-	-	456,0	-	-	444,0
54	-	-	388,0	-	-	399,0
58	-	-	336,0	-	-	361,0
62	-	-	-	354,0	-	328,5
66	-	-	-	328,0	-	297,0
70	-	-	-	305,0	-	266,5
71	-	-	-	300,0	-	259,2
74	-	-	-	-	-	239,5
78	-	-	-	-	234,0	215,0
82	-	-	-	-	219,0	191,5
86	-	-	-	-	-	170,0
90	-	-	-	-	-	150,0
94	-	-	-	-	-	137,0
98	-	-	-	-	-	122,0
100	-	-	-	-	-	113,0

78 m + 48 m

m	t	t	t	t	t	t
22	-	495,0*	-	-	-	-
24	-	495,0*	-	-	-	-
26	-	482,0*	-	-	-	-
28	-	470,0*	-	-	-	-
30	178,0	526,0	-	-	-	516,0
34	156,0	512,0	-	-	-	510,0
38	137,0	457,0	-	-	-	508,0
42	122,0	391,0	-	-	-	489,0
46	109,0	340,0	-	-	-	467,5
50	95,5	299,0	448,0	-	-	441,0
54	83,5	255,0	414,0	-	-	403,5
56	78,5	229,0	384,0	-	-	382,0
58	-	-	357,0	-	-	364,0
62	-	-	313,0	-	-	330,0
66	-	-	278,0	-	-	300,5
68	-	-	263,0	-	-	287,0
69	-	-	-	301,0	-	280,2
70	-	-	-	295,0	-	273,5
74	-	-	-	275,0	-	247,5
78	-	-	-	257,0	-	223,0
82	-	-	-	242,0	-	201,0
86	-	-	-	-	-	181,5
87	-	-	-	-	192,0	176,7
90	-	-	-	-	184,0	162,0
94	-	-	-	-	174,0	143,5
98	-	-	-	-	-	127,0
102	-	-	-	-	-	115,0
106	-	-	-	-	-	103,5
110	-	-	-	-	-	90,0
112	-	-	-	-	-	83,0

78 m + 60 m

m	SWSL					SFSL
	0 t		0 t-800 t			
	85°	85°	75°	65°	55°	t
26	-	409,0*	-	-	-	-
28	-	405,0*	-	-	-	-
30	-	397,0*	-	-	-	-
34	144,0	432,0	-	-	-	423,0
38	127,0	424,0	-	-	-	417,0
42	112,0	407,0	-	-	-	415,5
46	100,0	353,0	-	-	-	410,5
50	89,5	310,0	-	-	-	393,5
54	80,0	275,0	-	-	-	380,5
56	74,5	261,0	375,0	-	-	374,0
58	69,5	246,0	371,0	-	-	363,0
62	61,0	213,0	325,0	-	-	336,0
66	53,5	181,0	288,0	-	-	306,0
70	-	-	257,0	-	-	279,5
74	-	-	232,0	-	-	255,0
77	-	-	213,0	253,0	-	237,5
78	-	-	206,0	252,0	-	232,0
80	-	-	191,0	243,0	-	221,0
82	-	-	-	236,0	-	210,0
86	-	-	-	221,0	-	189,5
90	-	-	-	209,0	-	172,0
94	-	-	-	194,0	-	156,0
96	-	-	-	-	162,0	148,0
98	-	-	-	-	157,0	139,5
102	-	-	-	-	149,0	124,0
105	-	-	-	-	143,0	113,5
106	-	-	-	-	-	110,0
110	-	-	-	-	-	98,5
114	-	-	-	-	-	89,5
118	-	-	-	-	-	78,7
122	-	-	-	-	-	66,5
124	-	-	-	-	-	60,5
126	-	-	-	-	-	-

Remarks · Bemerkungen · Remarques

Main boom angle 88°, 85°, 75°, 65° and 55°; capacities for intermediate boom positions are calculated by the crane control system IC-1

Hauptauslegerwinkel 88°, 85°, 75°, 65° und 55°; Traglasten für Zwischenstellungen des Hauptauslegers werden von der Kransteuerung IC-1 berechnet

Jarret de flèche principale 88°, 85°, 75°, 65° et 55°; le système de commande de la grue IC-1 calcule les charges pour les positions intermédiaires de la flèche

* Main boom angle 88° · Hauptauslegerwinkel 88° · Jarret de flèche principale 88°





SWSL / SFSL 15° LIFTING CAPACITIES · TRAGFÄHIGKEITEN · CAPACITÉS DE LEVAGE

295 t + 60 t ZB 19-30 m 10,50 m 360° ISO

78 m + 72 m

m	SWSL					SFSL
	0 t		0 t-800 t			
	85°	85°	75°	65°	55°	t
30	-	336,0*	-	-	-	-
34	-	327,0*	-	-	-	-
38	116,0	353,0	-	-	-	346,0
42	103,0	350,0	-	-	-	343,5
46	91,0	341,0	-	-	-	341,5
50	81,0	320,0	-	-	-	340,0
54	72,0	284,0	-	-	-	332,0
58	64,5	253,0	-	-	-	318,5
62	57,5	226,0	317,0	-	-	309,0
66	50,0	200,0	296,0	-	-	296,5
70	43,5	176,0	264,0	-	-	280,0
74	37,5	153,0	237,0	-	-	260,0
78	33,0	131,0	214,0	-	-	238,5
82	-	-	194,0	-	-	217,5
86	-	-	172,0	216,0	-	198,0
90	-	-	151,0	203,0	-	180,0
92	-	-	140,0	197,0	-	171,0
94	-	-	-	191,0	-	162,5
98	-	-	-	180,0	-	147,5
102	-	-	-	165,0	-	134,0
104	-	-	-	155,0	-	127,0
105	-	-	-	-	136,0	123,5
106	-	-	-	-	134,0	120,0
110	-	-	-	-	127,0	107,0
114	-	-	-	-	120,0	94,7
117	-	-	-	-	116,0	85,7
118	-	-	-	-	-	84,0
122	-	-	-	-	-	76,5
126	-	-	-	-	-	67,2
130	-	-	-	-	-	57,0
134	-	-	-	-	-	46,7
136	-	-	-	-	-	41,5
140	-	-	-	-	-	-

78 m + 84 m

m	SWSL					SFSL
	0 t		0 t-800 t			
	85°	85°	75°	65°	55°	t
34	-	274,0*	-	-	-	-
38	-	269,0*	-	-	-	-
42	93,5	284,0	-	-	-	-
44	87,5	284,0	-	-	-	277,0
46	82,0	282,0	-	-	-	276,5
50	72,5	277,0	-	-	-	275,5
54	64,0	272,0	-	-	-	274,0
58	56,5	254,0	-	-	-	270,5
62	50,0	228,0	-	-	-	265,0
66	44,0	206,0	-	-	-	260,0
68	41,5	196,0	263,0	-	-	258,0
70	38,5	187,0	263,0	-	-	253,0
74	34,0	167,0	237,0	-	-	241,5
78	29,5	149,0	214,0	-	-	228,5
82	25,2	132,0	194,0	-	-	216,5
84	23,0	124,0	185,0	-	-	211,0
86	-	115,5	176,0	-	-	203,5
88	-	107,0	168,0	-	-	196,0
90	-	-	161,0	-	-	187,0
92	-	-	154,0	183,0	-	178,0
94	-	-	147,0	183,0	-	170,0
98	-	-	131,0	176,0	-	154,5
102	-	-	115,0	165,0	-	140,0
104	-	-	107,0	157,0	-	133,0
106	-	-	-	151,0	-	127,5
110	-	-	-	139,0	-	115,5
114	-	-	-	127,0	115,0	103,0
116	-	-	-	119,0	111,0	97,0
118	-	-	-	-	108,0	91,7
122	-	-	-	-	103,0	81,2
126	-	-	-	-	97,5	71,2
128	-	-	-	-	95,0	68,0
130	-	-	-	-	-	64,7
134	-	-	-	-	-	57,0
138	-	-	-	-	-	48,0
142	-	-	-	-	-	39,2
146	-	-	-	-	-	30,2
148	-	-	-	-	-	25,5
150	-	-	-	-	-	-

Remarks · Bemerkungen · Remarques

Main boom angle 88°, 85°, 75°, 65° and 55°; capacities for intermediate boom positions are calculated by the crane control system IC-1

Hauptauslegerwinkel 88°, 85°, 75°, 65° und 55°; Traglasten für Zwischenstellungen des Hauptauslegers werden von der Kransteuerung IC-1 berechnet

Jarret de flèche principale 88°, 85°, 75°, 65° et 55°; le système de commande de la grue IC-1 calcule les charges pour les positions intermédiaires de la flèche

* Main boom angle 88° · Hauptauslegerwinkel 88° · Jarret de flèche principale 88°





SWSL / SFSL 15° LIFTING CAPACITIES · TRAGFÄHIGKEITEN · CAPACITÉS DE LEVAGE

295 t + 60 t ZB 19-30 m 10,50 m 360° ISO

78 m + 96 m

m	SWSL					SFSL
	0 t		0 t-800 t			
	85°	85°	75°	65°	55°	t
36	-	219,0*	-	-	-	-
38	-	219,0*	-	-	-	-
42	-	215,0*	-	-	-	-
46	74,5	224,0	-	-	-	-
48	70,0	224,0	-	-	-	219,0
50	65,5	222,0	-	-	-	218,0
54	57,0	218,0	-	-	-	216,0
58	50,0	212,0	-	-	-	214,0
62	43,5	206,0	-	-	-	211,5
66	38,0	200,0	-	-	-	207,5
70	33,0	186,0	-	-	-	203,0
74	28,0	169,0	208,0	-	-	199,5
78	24,0	154,0	207,0	-	-	193,5
80	22,0	147,0	202,0	-	-	189,0
82	-	139,5	193,0	-	-	185,0
86	-	125,5	175,0	-	-	177,5
90	-	112,5	160,0	-	-	170,5
94	-	99,7	146,0	-	-	163,5
98	-	87,2	134,0	-	-	156,5
100	-	81,0	128,0	159,0	-	153,0
102	-	-	123,0	159,0	-	146,0
106	-	-	112,0	149,0	-	133,0
110	-	-	100,0	137,0	-	120,5
114	-	-	88,0	126,0	-	108,5
118	-	-	-	116,0	-	98,2
122	-	-	-	107,0	-	88,5
124	-	-	-	103,0	95,0	83,5
126	-	-	-	98,0	92,0	78,5
128	-	-	-	92,0	89,5	73,5
130	-	-	-	-	87,0	68,7
134	-	-	-	-	82,5	59,7
138	-	-	-	-	78,0	54,0
140	-	-	-	-	76,0	51,0
142	-	-	-	-	-	47,5
146	-	-	-	-	-	40,0
150	-	-	-	-	-	31,7
154	-	-	-	-	-	23,7
156	-	-	-	-	-	20,0
158	-	-	-	-	-	-

78 m + 108 m

m	SWSL					SFSL
	0 t		0 t-800 t			
	85°	85°	75°	65°	55°	t
40	-	172,0*	-	-	-	-
42	-	172,0*	-	-	-	-
46	-	167,0*	-	-	-	-
50	58,0	172,0	-	-	-	-
52	54,0	172,0	-	-	-	168,0
54	50,0	170,0	-	-	-	166,5
58	43,5	166,0	-	-	-	164,0
62	37,0	162,0	-	-	-	162,0
66	31,5	158,0	-	-	-	159,5
70	27,0	153,0	-	-	-	156,0
74	22,5	149,0	-	-	-	152,5
76	20,0	147,0	-	-	-	151,0
78	-	145,0	-	-	-	149,5
80	-	143,0	154,0	-	-	148,0
82	-	138,5	154,0	-	-	145,5
86	-	128,5	153,0	-	-	141,0
90	-	117,0	150,0	-	-	137,0
94	-	105,5	145,0	-	-	133,5
98	-	95,0	132,0	-	-	130,0
102	-	85,0	121,0	-	-	126,5
106	-	75,0	112,0	-	-	123,0
108	-	70,0	107,0	124,0	-	121,0
110	-	65,0	103,0	124,0	-	119,5
112	-	60,0	99,0	124,0	-	118,0
114	-	-	95,0	124,0	-	113,0
118	-	-	85,5	114,0	-	103,0
122	-	-	76,2	105,0	-	93,0
126	-	-	66,5	97,0	-	83,7
130	-	-	-	89,5	-	75,0
134	-	-	-	82,5	77,5	66,0
138	-	-	-	75,0	73,0	57,2
142	-	-	-	-	69,0	49,5
146	-	-	-	-	65,0	44,7
150	-	-	-	-	61,5	39,0
154	-	-	-	-	-	31,7
158	-	-	-	-	-	24,5
160	-	-	-	-	-	21,0
162	-	-	-	-	-	-
166	-	-	-	-	-	-

Remarks · Bemerkungen · Remarques

Main boom angle 88°, 85°, 75°, 65° and 55°; capacities for intermediate boom positions are calculated by the crane control system IC-1
 Hauptauslegerwinkel 88°, 85°, 75°, 65° und 55°; Traglasten für Zwischenstellungen des Hauptauslegers werden von der Kransteuerung IC-1 berechnet
 Jarret de flèche principale 88°, 85°, 75°, 65° et 55°; le système de commande de la grue IC-1 calcule les charges pour les positions intermédiaires de la flèche

* Main boom angle 88° · Hauptauslegerwinkel 88° · Jarret de flèche principale 88°





SWSL / SFSL 15° LIFTING CAPACITIES · TRAGFÄHIGKEITEN · CAPACITÉS DE LEVAGE

295 t + 60 t ZB 19-30 m 10,50 m 360° ISO

78 m + 120 m

m	SWSL					SFSL
	0 t		0 t-800 t			
	85°	85°	75°	65°	55°	t
44	-	127,0*	-	-	-	-
46	-	127,0*	-	-	-	-
50	-	124,0*	-	-	-	-
54	43,5	126,0	-	-	-	-
56	40,0	126,0	-	-	-	125,0
58	36,5	125,0	-	-	-	124,0
62	31,0	122,0	-	-	-	122,5
66	25,5	119,0	-	-	-	120,5
70	20,5	116,0	-	-	-	118,0
74	-	112,0	-	-	-	116,0
78	-	106,0	-	-	-	113,5
82	-	101,0	-	-	-	110,0
86	-	95,2	108,0	-	-	107,0
90	-	89,7	108,0	-	-	104,0
94	-	84,5	104,0	-	-	100,5
98	-	79,5	99,0	-	-	97,2
102	-	74,5	93,5	-	-	93,5
106	-	69,7	88,5	-	-	90,5
110	-	65,0	83,0	-	-	88,0
114	-	59,7	77,5	-	-	85,0
116	-	57,0	75,0	83,0	-	83,5
118	-	53,0	72,0	83,0	-	81,7
122	-	45,0	67,5	81,5	-	78,5
124	-	41,0	65,0	79,5	-	77,0
126	-	-	63,0	77,5	-	75,5
130	-	-	58,5	72,5	-	72,7
134	-	-	54,0	68,0	-	68,0
138	-	-	47,0	63,5	-	60,5
142	-	-	-	59,5	62,0	52,5
146	-	-	-	55,5	58,0	44,7
150	-	-	-	51,5	54,5	39,0
154	-	-	-	-	51,0	34,0
158	-	-	-	-	48,0	28,2
160	-	-	-	-	46,5	25,0
162	-	-	-	-	-	-

84 m + 36 m

m	SWSL					SFSL
	0 t		0 t-800 t			
	85°	85°	75°	65°	55°	t
20	-	562,0*	-	-	-	-
22	-	546,0*	-	-	-	-
24	-	529,0*	-	-	-	-
26	213,0	589,0	-	-	-	580,0
28	198,0	583,0	-	-	-	577,0
30	184,0	571,0	-	-	-	576,0
34	161,0	523,0	-	-	-	574,0
38	143,0	436,0	-	-	-	549,0
42	127,0	372,0	-	-	-	523,5
44	120,0	347,0	-	-	-	511,0
45	-	-	500,0	-	-	499,0
46	-	-	500,0	-	-	487,0
50	-	-	475,0	-	-	439,0
54	-	-	410,0	-	-	394,5
58	-	-	353,0	-	-	356,0
62	-	-	-	-	-	322,5
64	-	-	-	330,0	-	307,0
66	-	-	-	321,0	-	293,5
70	-	-	-	298,0	-	266,0
73	-	-	-	283,0	-	246,0
74	-	-	-	-	-	240,0
78	-	-	-	-	-	216,5
81	-	-	-	-	216,0	199,5
82	-	-	-	-	213,0	194,0
86	-	-	-	-	200,0	173,0
90	-	-	-	-	-	153,0
94	-	-	-	-	-	134,0
98	-	-	-	-	-	119,0
102	-	-	-	-	-	107,5
106	-	-	-	-	-	93,5
108	-	-	-	-	-	86,0

Remarks · Bemerkungen · Remarques

Main boom angle 88°, 85°, 75°, 65° and 55°; capacities for intermediate boom positions are calculated by the crane control system IC-1
 Hauptauslegerwinkel 88°, 85°, 75°, 65° und 55°; Traglasten für Zwischenstellungen des Hauptauslegers werden von der Kransteuerung IC-1 berechnet
 Jarret de flèche principale 88°, 85°, 75°, 65° et 55°; le système de commande de la grue IC-1 calcule les charges pour les positions intermédiaires de la flèche

* Main boom angle 88° · Hauptauslegerwinkel 88° · Jarret de flèche principale 88°





SWSL / SFSL 15° LIFTING CAPACITIES · TRAGFÄHIGKEITEN · CAPACITÉS DE LEVAGE

295 t + 60 t ZB 19-30 m 10,50 m 360° ISO

84 m + 48 m

m	SWSL					SFSL
	0 t		0 t-800 t			
	85°	85°	75°	65°	55°	t
24	-	457,0*	-	-	-	-
26	-	445,0*	-	-	-	-
28	-	434,0*	-	-	-	-
30	170,0	483,0	-	-	-	474,0
34	148,0	471,0	-	-	-	469,0
38	130,0	454,0	-	-	-	467,0
42	116,0	398,0	-	-	-	460,0
46	103,0	345,0	-	-	-	438,0
50	92,5	303,0	-	-	-	421,0
52	86,5	285,0	421,0	-	-	413,0
54	80,5	262,0	421,0	-	-	395,0
56	75,5	237,0	406,0	-	-	377,0
58	-	-	377,0	-	-	359,0
62	-	-	328,0	-	-	325,5
66	-	-	290,0	-	-	296,0
70	-	-	259,0	-	-	270,0
72	-	-	-	278,0	-	258,0
74	-	-	-	268,0	-	246,0
78	-	-	-	251,0	-	222,5
82	-	-	-	235,0	-	200,5
84	-	-	-	228,0	-	190,0
86	-	-	-	-	-	180,5
90	-	-	-	-	177,0	162,0
94	-	-	-	-	167,0	145,0
97	-	-	-	-	160,0	133,0
98	-	-	-	-	-	129,0
102	-	-	-	-	-	113,5
106	-	-	-	-	-	99,0
110	-	-	-	-	-	90,5
114	-	-	-	-	-	79,7
118	-	-	-	-	-	67,0
120	-	-	-	-	-	60,5
122	-	-	-	-	-	-

84 m + 60 m

m	SWSL					SFSL
	0 t		0 t-800 t			
	85°	85°	75°	65°	55°	t
26	-	379,0*	-	-	-	-
28	-	375,0*	-	-	-	-
30	-	367,0*	-	-	-	-
34	137,0	397,0	-	-	-	390,0
38	120,0	392,0	-	-	-	386,0
42	106,0	380,0	-	-	-	384,5
46	95,0	358,0	-	-	-	381,5
50	84,5	314,0	-	-	-	372,0
54	76,0	279,0	-	-	-	358,0
58	67,0	249,0	357,0	-	-	346,0
62	58,5	217,0	341,0	-	-	327,5
66	51,5	186,0	300,0	-	-	302,0
68	48,0	169,0	283,0	-	-	288,0
70	-	-	267,0	-	-	275,0
74	-	-	240,0	-	-	251,0
78	-	-	217,0	-	-	229,5
80	-	-	203,0	237,0	-	219,0
82	-	-	187,0	229,0	-	208,5
86	-	-	-	215,0	-	188,5
90	-	-	-	203,0	-	170,5
94	-	-	-	191,0	-	154,5
96	-	-	-	186,0	-	147,0
98	-	-	-	-	-	139,5
99	-	-	-	-	149,0	135,7
102	-	-	-	-	143,0	125,0
106	-	-	-	-	135,0	111,0
109	-	-	-	-	130,0	100,7
110	-	-	-	-	-	97,5
114	-	-	-	-	-	85,0
118	-	-	-	-	-	77,0
122	-	-	-	-	-	68,5
126	-	-	-	-	-	58,0
128	-	-	-	-	-	52,5

Remarks · Bemerkungen · Remarques

Main boom angle 88°, 85°, 75°, 65° and 55°; capacities for intermediate boom positions are calculated by the crane control system IC-1

Hauptauslegerwinkel 88°, 85°, 75°, 65° und 55°; Traglasten für Zwischenstellungen des Hauptauslegers werden von der Kransteuerung IC-1 berechnet

Jarret de flèche principale 88°, 85°, 75°, 65° et 55°; le système de commande de la grue IC-1 calcule les charges pour les positions intermédiaires de la flèche

* Main boom angle 88° · Hauptauslegerwinkel 88° · Jarret de flèche principale 88°





SWSL / SFSL 15° LIFTING CAPACITIES · TRAGFÄHIGKEITEN · CAPACITÉS DE LEVAGE

295 t + 60 t ZB 19-30 m 10,50 m 360° ISO

84 m + 72 m

m	SWSL					SFSL
	0 t		0 t-800 t			
	85°	85°	75°	65°	55°	t
30	-	312,0*	-	-	-	-
34	-	304,0*	-	-	-	-
38	110,0	328,0	-	-	-	321,0
42	97,0	325,0	-	-	-	318,5
46	85,5	317,0	-	-	-	317,5
50	76,0	309,0	-	-	-	316,0
54	67,5	287,0	-	-	-	310,5
58	60,0	257,0	-	-	-	302,0
62	53,5	230,0	-	-	-	294,0
64	50,5	216,0	299,0	-	-	291,0
66	47,5	203,0	299,0	-	-	285,0
70	41,0	179,0	275,0	-	-	271,5
74	35,5	156,0	247,0	-	-	254,5
78	31,0	134,0	223,0	-	-	235,0
82	-	-	202,0	-	-	215,0
86	-	-	181,0	-	-	196,0
88	-	-	170,0	199,0	-	187,0
90	-	-	159,0	197,0	-	178,5
94	-	-	137,0	185,0	-	161,5
98	-	-	-	175,0	-	146,0
102	-	-	-	165,0	-	132,5
106	-	-	-	157,0	-	119,5
109	-	-	-	-	123,0	110,0
110	-	-	-	-	121,0	107,0
114	-	-	-	-	115,0	95,2
118	-	-	-	-	109,0	83,7
120	-	-	-	-	106,0	78,0
122	-	-	-	-	-	72,5
126	-	-	-	-	-	64,5
130	-	-	-	-	-	57,5
134	-	-	-	-	-	48,5
138	-	-	-	-	-	38,7
140	-	-	-	-	-	34,0

84 m + 84 m

m	SWSL					SFSL
	0 t		0 t-800 t			
	85°	85°	75°	65°	55°	t
34	-	256,0*	-	-	-	-
38	-	250,0*	-	-	-	-
42	87,5	267,0	-	-	-	-
44	82,0	267,0	-	-	-	260,0
46	77,0	265,0	-	-	-	259,5
50	67,5	261,0	-	-	-	258,5
54	59,5	256,0	-	-	-	257,5
58	52,5	249,0	-	-	-	255,0
62	46,0	233,0	-	-	-	250,0
66	40,5	210,0	-	-	-	244,0
70	35,0	190,0	248,0	-	-	238,5
74	30,5	169,0	246,0	-	-	229,5
78	26,5	151,0	224,0	-	-	219,0
82	22,7	134,0	203,0	-	-	208,5
84	21,0	126,0	193,0	-	-	203,0
86	-	118,0	185,0	-	-	198,0
88	-	110,0	176,0	-	-	193,0
90	-	-	169,0	-	-	184,5
94	-	-	153,0	-	-	168,0
96	-	-	145,0	172,0	-	160,0
98	-	-	137,0	171,0	-	153,0
102	-	-	121,0	161,0	-	139,0
104	-	-	113,0	156,0	-	132,0
106	-	-	-	152,0	-	125,5
110	-	-	-	144,0	-	113,5
114	-	-	-	136,0	-	102,5
118	-	-	-	121,0	103,0	91,7
122	-	-	-	-	98,0	81,2
126	-	-	-	-	92,5	71,0
130	-	-	-	-	87,5	61,0
132	-	-	-	-	85,5	56,5
134	-	-	-	-	-	53,5
138	-	-	-	-	-	47,2
142	-	-	-	-	-	39,7
146	-	-	-	-	-	31,5
148	-	-	-	-	-	27,5
150	-	-	-	-	-	-

Remarks · Bemerkungen · Remarques

Main boom angle 88°, 85°, 75°, 65° and 55°; capacities for intermediate boom positions are calculated by the crane control system IC-1

Hauptauslegerwinkel 88°, 85°, 75°, 65° und 55°; Traglasten für Zwischenstellungen des Hauptauslegers werden von der Kransteuerung IC-1 berechnet

Jarret de flèche principale 88°, 85°, 75°, 65° et 55°; le système de commande de la grue IC-1 calcule les charges pour les positions intermédiaires de la flèche

* Main boom angle 88° · Hauptauslegerwinkel 88° · Jarret de flèche principale 88°





SWSL / SFSL 15° LIFTING CAPACITIES · TRAGFÄHIGKEITEN · CAPACITÉS DE LEVAGE

295 t + 60 t ZB 19-30 m 10,50 m 360° ISO

84 m + 96 m

m	SWSL					SFSL
	0 t		0 t-800 t			
	85°	85°	75°	65°	55°	t
38	-	207,0*	-	-	-	-
42	-	203,0*	-	-	-	-
46	69,5	212,0	-	-	-	-
48	64,5	212,0	-	-	-	206,0
50	60,5	211,0	-	-	-	206,0
54	52,5	207,0	-	-	-	205,5
58	46,0	202,0	-	-	-	204,5
62	39,5	197,0	-	-	-	203,0
66	34,0	192,0	-	-	-	200,0
70	29,5	186,0	-	-	-	196,0
74	25,0	174,0	-	-	-	192,0
76	23,0	166,0	197,0	-	-	190,0
78	21,0	158,0	197,0	-	-	187,0
82	-	141,5	196,0	-	-	180,5
86	-	127,0	184,0	-	-	172,0
90	-	113,5	168,0	-	-	165,0
94	-	101,0	154,0	-	-	158,5
98	-	89,0	141,0	-	-	152,5
100	-	83,0	135,0	-	-	150,0
102	-	-	130,0	-	-	143,5
104	-	-	123,0	149,0	-	137,0
106	-	-	117,0	148,0	-	131,0
110	-	-	104,0	139,0	-	119,0
114	-	-	92,5	132,0	-	107,5
116	-	-	86,5	128,0	-	102,0
118	-	-	-	125,0	-	97,0
122	-	-	-	115,0	-	87,2
126	-	-	-	105,0	-	77,7
128	-	-	-	99,5	85,0	73,0
130	-	-	-	93,5	82,5	68,5
134	-	-	-	-	77,5	59,5
138	-	-	-	-	73,5	50,5
142	-	-	-	-	69,5	44,2
146	-	-	-	-	-	38,7
150	-	-	-	-	-	31,7
154	-	-	-	-	-	24,2
156	-	-	-	-	-	20,5

84 m + 108 m

m	SWSL					SFSL
	0 t		0 t-800 t			
	85°	85°	75°	65°	55°	t
40	-	162,0*	-	-	-	-
42	-	162,0*	-	-	-	-
46	-	159,0*	-	-	-	-
50	53,0	163,0	-	-	-	-
52	49,5	163,0	-	-	-	159,0
54	46,0	162,0	-	-	-	158,5
58	39,0	159,0	-	-	-	157,0
62	33,5	155,0	-	-	-	155,0
66	28,0	151,0	-	-	-	153,0
70	23,5	147,0	-	-	-	150,5
72	21,0	145,0	-	-	-	149,0
74	-	143,0	-	-	-	147,5
78	-	139,0	-	-	-	144,0
82	-	135,0	148,0	-	-	141,0
86	-	129,0	148,0	-	-	137,0
90	-	119,0	146,0	-	-	132,5
94	-	107,5	144,0	-	-	128,5
98	-	96,7	140,0	-	-	125,0
102	-	86,5	129,0	-	-	121,0
106	-	76,5	118,0	-	-	117,5
110	-	66,5	109,0	117,0	-	114,0
112	-	61,5	104,0	117,0	-	112,0
114	-	-	99,0	117,0	-	109,0
118	-	-	89,5	115,0	-	101,0
122	-	-	80,0	113,0	-	91,2
126	-	-	70,5	105,0	-	82,0
128	-	-	65,5	101,0	-	77,5
130	-	-	-	97,0	-	73,2
134	-	-	-	90,0	-	64,7
136	-	-	-	85,5	70,5	60,5
138	-	-	-	81,0	68,5	56,5
142	-	-	-	71,5	64,5	48,5
146	-	-	-	-	60,5	40,7
150	-	-	-	-	57,0	34,7
154	-	-	-	-	53,5	29,7
158	-	-	-	-	-	24,0
160	-	-	-	-	-	20,5

Remarks · Bemerkungen · Remarques

Main boom angle 88°, 85°, 75°, 65° and 55°; capacities for intermediate boom positions are calculated by the crane control system IC-1
 Hauptauslegerwinkel 88°, 85°, 75°, 65° und 55°; Traglasten für Zwischenstellungen des Hauptauslegers werden von der Kransteuerung IC-1 berechnet
 Jarret de flèche principale 88°, 85°, 75°, 65° et 55°; le système de commande de la grue IC-1 calcule les charges pour les positions intermédiaires de la flèche

* Main boom angle 88° · Hauptauslegerwinkel 88° · Jarret de flèche principale 88°





SWSL / SFSL 15° LIFTING CAPACITIES · TRAGFÄHIGKEITEN · CAPACITÉS DE LEVAGE

295 t + 60 t ZB 19-30 m 10,50 m 360° ISO

84 m + 120 m

90 m + 36 m

m	SWSL					SFSL
	0 t		0 t-800 t			
	85°	85°	75°	65°	55°	t
44	-	122,0*	-	-	-	-
46	-	122,0*	-	-	-	-
50	-	119,0*	-	-	-	-
54	39,0	121,0	-	-	-	-
56	35,5	121,0	-	-	-	119,0
58	32,5	120,0	-	-	-	118,5
62	27,0	117,0	-	-	-	117,0
66	21,5	115,0	-	-	-	115,0
70	-	112,0	-	-	-	113,5
74	-	108,0	-	-	-	111,5
78	-	103,0	-	-	-	108,5
82	-	98,5	-	-	-	106,0
86	-	93,5	-	-	-	103,5
88	-	91,0	105,0	-	-	102,0
90	-	88,5	105,0	-	-	101,0
94	-	83,5	103,0	-	-	98,2
98	-	78,5	99,0	-	-	94,7
102	-	73,7	94,5	-	-	91,2
106	-	69,2	89,5	-	-	88,2
110	-	64,5	84,5	-	-	85,7
114	-	59,7	79,0	-	-	83,2
118	-	53,7	74,0	81,5	-	80,7
122	-	46,0	68,5	81,5	-	78,0
124	-	42,0	66,5	80,5	-	76,5
126	-	-	64,5	79,0	-	75,2
130	-	-	60,0	75,0	-	72,0
134	-	-	56,0	70,5	-	66,0
138	-	-	50,0	66,0	-	58,5
142	-	-	-	61,5	-	51,0
146	-	-	-	57,5	53,5	43,5
150	-	-	-	53,5	50,0	36,5
154	-	-	-	-	46,5	29,5
158	-	-	-	-	43,5	23,5
160	-	-	-	-	42,0	21,0
162	-	-	-	-	40,7	-
164	-	-	-	-	39,5	-
166	-	-	-	-	-	-

m	SWSL					SFSL
	0 t		0 t-800 t			
	85°	85°	75°	65°	55°	t
20	-	514,0*	-	-	-	-
22	-	499,0*	-	-	-	-
24	-	485,0*	-	-	-	-
26	204,0	536,0	-	-	-	527,0
28	189,0	531,0	-	-	-	525,0
30	176,0	520,0	-	-	-	524,0
34	154,0	498,0	-	-	-	521,0
38	137,0	445,0	-	-	-	515,0
42	122,0	379,0	-	-	-	487,5
44	115,0	352,0	-	-	-	478,0
46	-	-	-	-	-	468,5
47	-	-	467,0	-	-	463,7
50	-	-	461,0	-	-	435,5
54	-	-	430,0	-	-	391,0
58	-	-	372,0	-	-	352,0
60	-	-	346,0	-	-	334,0
62	-	-	-	-	-	318,5
66	-	-	-	-	-	289,5
67	-	-	-	307,0	-	282,7
70	-	-	-	291,0	-	264,0
74	-	-	-	272,0	-	239,0
76	-	-	-	263,0	-	226,0
78	-	-	-	-	-	215,5
82	-	-	-	-	-	194,5
84	-	-	-	-	200,0	184,0
86	-	-	-	-	194,0	174,0
89	-	-	-	-	185,0	159,5
90	-	-	-	-	-	155,0
94	-	-	-	-	-	137,5
98	-	-	-	-	-	121,0
102	-	-	-	-	-	105,2
106	-	-	-	-	-	95,2
110	-	-	-	-	-	84,0
112	-	-	-	-	-	77,0
114	-	-	-	-	-	-

Remarks · Bemerkungen · Remarques

Main boom angle 88°, 85°, 75°, 65° and 55°; capacities for intermediate boom positions are calculated by the crane control system IC-1
 Hauptauslegerwinkel 88°, 85°, 75°, 65° und 55°; Traglasten für Zwischenstellungen des Hauptauslegers werden von der Kransteuerung IC-1 berechnet
 Jarret de fleche principale 88°, 85°, 75°, 65° et 55°; le systeme de commande de la grue IC-1 calcule les charges pour les positions intermediaires de la fleche

* Main boom angle 88° · Hauptauslegerwinkel 88° · Jarret de fleche principale 88°





SWSL / SFSL 15° LIFTING CAPACITIES · TRAGFÄHIGKEITEN · CAPACITÉS DE LEVAGE

295 t + 60 t ZB 19-30 m 10,50 m 360° ISO

90 m + 48 m

m	SWSL					SFSL
	0 t		0 t-800 t			
	85°	85°	75°	65°	55°	t
24	-	418,0*	-	-	-	-
26	-	408,0*	-	-	-	-
28	-	397,0*	-	-	-	-
30	162,0	438,0	-	-	-	430,0
34	141,0	430,0	-	-	-	429,0
38	124,0	415,0	-	-	-	427,0
42	110,0	398,0	-	-	-	422,5
46	98,5	350,0	-	-	-	410,0
50	88,5	307,0	-	-	-	395,0
54	78,0	268,0	393,0	-	-	381,5
56	73,0	243,0	388,0	-	-	374,0
58	-	-	379,0	-	-	356,0
62	-	-	344,0	-	-	322,0
66	-	-	303,0	-	-	292,0
70	-	-	269,0	-	-	266,0
72	-	-	254,0	-	-	254,0
74	-	-	-	258,0	-	243,0
78	-	-	-	244,0	-	220,5
82	-	-	-	229,0	-	198,5
86	-	-	-	215,0	-	179,5
90	-	-	-	-	-	162,5
94	-	-	-	-	161,0	146,0
98	-	-	-	-	152,0	130,0
101	-	-	-	-	146,0	118,5
102	-	-	-	-	-	115,0
106	-	-	-	-	-	101,0
110	-	-	-	-	-	87,7
114	-	-	-	-	-	78,0
118	-	-	-	-	-	69,0
122	-	-	-	-	-	58,0
124	-	-	-	-	-	52,0

90 m + 60 m

m	SWSL					SFSL
	0 t		0 t-800 t			
	85°	85°	75°	65°	55°	t
26	-	344,0*	-	-	-	-
28	-	344,0*	-	-	-	-
30	-	337,0*	-	-	-	-
34	130,0	363,0	-	-	-	356,0
38	114,0	358,0	-	-	-	353,0
42	101,0	347,0	-	-	-	351,5
46	90,0	336,0	-	-	-	350,0
50	80,0	319,0	-	-	-	344,0
54	71,5	282,0	-	-	-	332,5
58	64,5	252,0	-	-	-	326,0
60	60,0	238,0	328,0	-	-	323,0
62	56,0	221,0	328,0	-	-	315,0
66	49,0	190,0	314,0	-	-	295,5
68	46,0	173,0	295,0	-	-	284,0
70	-	-	279,0	-	-	271,5
74	-	-	249,0	-	-	247,5
78	-	-	225,0	-	-	226,0
82	-	-	199,0	223,0	-	206,0
84	-	-	183,0	216,0	-	196,0
86	-	-	-	209,0	-	187,0
90	-	-	-	196,0	-	169,5
94	-	-	-	185,0	-	152,5
98	-	-	-	175,0	-	138,0
102	-	-	-	-	-	125,0
103	-	-	-	-	135,0	121,5
106	-	-	-	-	129,0	111,0
110	-	-	-	-	122,0	98,0
112	-	-	-	-	119,0	92,0
114	-	-	-	-	-	86,2
118	-	-	-	-	-	74,7
122	-	-	-	-	-	65,2
126	-	-	-	-	-	57,7
130	-	-	-	-	-	49,0
134	-	-	-	-	-	39,0
136	-	-	-	-	-	34,0

Remarks · Bemerkungen · Remarques

Main boom angle 88°, 85°, 75°, 65° and 55°; capacities for intermediate boom positions are calculated by the crane control system IC-1

Hauptauslegerwinkel 88°, 85°, 75°, 65° und 55°; Traglasten für Zwischenstellungen des Hauptauslegers werden von der Kransteuerung IC-1 berechnet

Jarret de flèche principale 88°, 85°, 75°, 65° et 55°; le système de commande de la grue IC-1 calcule les charges pour les positions intermédiaires de la flèche

* Main boom angle 88° · Hauptauslegerwinkel 88° · Jarret de flèche principale 88°





SWSL / SFSL 15° LIFTING CAPACITIES · TRAGFÄHIGKEITEN · CAPACITÉS DE LEVAGE

295 t + 60 t ZB 19-30 m 10,50 m 360° ISO

90 m + 72 m

m	SWSL					SFSL
	0 t - 800 t					
	85°	85°	75°	65°	55°	t
30	-	287,0*	-	-	-	-
34	-	280,0*	-	-	-	-
38	104,0	299,0	-	-	-	294,0
42	91,5	298,0	-	-	-	292,5
46	80,5	291,0	-	-	-	291,5
50	71,5	284,0	-	-	-	290,0
54	63,5	275,0	-	-	-	286,5
58	56,5	259,0	-	-	-	281,0
62	50,0	233,0	-	-	-	275,0
66	44,5	206,0	281,0	-	-	269,0
70	39,0	181,0	276,0	-	-	258,5
74	33,5	159,0	256,0	-	-	246,0
78	29,0	137,0	231,0	-	-	230,5
80	27,0	125,0	219,0	-	-	221,0
82	-	-	209,0	-	-	211,5
86	-	-	189,0	-	-	193,0
90	-	-	167,0	188,0	-	175,5
94	-	-	146,0	180,0	-	159,0
98	-	-	-	169,0	-	144,0
102	-	-	-	160,0	-	130,0
106	-	-	-	151,0	-	117,5
110	-	-	-	143,0	-	106,0
112	-	-	-	-	112,0	100,0
114	-	-	-	-	109,0	94,5
118	-	-	-	-	103,0	83,5
122	-	-	-	-	98,5	72,7
124	-	-	-	-	96,0	67,5
126	-	-	-	-	-	62,5
130	-	-	-	-	-	53,7
134	-	-	-	-	-	47,5
138	-	-	-	-	-	40,2
142	-	-	-	-	-	31,2
144	-	-	-	-	-	26,5

90 m + 84 m

m	SWSL					SFSL
	0 t - 800 t					
	85°	85°	75°	65°	55°	t
34	-	236,0*	-	-	-	-
38	-	231,0*	-	-	-	-
42	82,0	246,0	-	-	-	-
44	77,0	246,0	-	-	-	241,0
46	72,0	245,0	-	-	-	240,0
50	63,0	241,0	-	-	-	238,5
54	55,0	236,0	-	-	-	237,5
58	48,5	230,0	-	-	-	236,0
62	42,5	224,0	-	-	-	232,5
66	37,0	212,0	-	-	-	228,0
70	32,0	193,0	-	-	-	223,5
72	30,0	182,0	231,0	-	-	222,0
74	27,5	172,0	231,0	-	-	217,5
78	23,5	153,0	227,0	-	-	208,5
80	22,0	145,0	221,0	-	-	204,0
82	-	136,5	210,0	-	-	199,0
86	-	120,0	191,0	-	-	189,5
88	-	112,0	182,0	-	-	185,0
90	-	-	174,0	-	-	179,0
94	-	-	159,0	-	-	165,5
98	-	-	143,0	163,0	-	151,0
102	-	-	127,0	156,0	-	137,0
106	-	-	111,0	147,0	-	124,0
110	-	-	-	139,0	-	111,5
114	-	-	-	131,0	-	100,5
118	-	-	-	124,0	-	91,0
120	-	-	-	121,0	-	86,0
122	-	-	-	-	93,0	80,7
126	-	-	-	-	87,5	70,5
130	-	-	-	-	83,0	61,0
134	-	-	-	-	78,5	52,2
138	-	-	-	-	-	44,5
142	-	-	-	-	-	38,7
146	-	-	-	-	-	32,0
150	-	-	-	-	-	24,0
152	-	-	-	-	-	20,0
154	-	-	-	-	-	-

Remarks · Bemerkungen · Remarques

Main boom angle 88°, 85°, 75°, 65° and 55°; capacities for intermediate boom positions are calculated by the crane control system IC-1

Hauptauslegerwinkel 88°, 85°, 75°, 65° und 55°; Traglasten für Zwischenstellungen des Hauptauslegers werden von der Kransteuerung IC-1 berechnet

Jarret de flèche principale 88°, 85°, 75°, 65° et 55°; le système de commande de la grue IC-1 calcule les charges pour les positions intermédiaires de la flèche

* Main boom angle 88° · Hauptauslegerwinkel 88° · Jarret de flèche principale 88°





SWSL / SFSL 15° LIFTING CAPACITIES · TRAGFÄHIGKEITEN · CAPACITÉS DE LEVAGE

295 t + 60 t ZB 19-30 m 10,50 m 360° ISO

90 m + 96 m

m	SWSL					SFSL
	0 t		0 t-800 t			
	85°	85°	75°	65°	55°	t
38	-	193,0*	-	-	-	-
42	-	189,0*	-	-	-	-
46	64,5	198,0	-	-	-	-
48	60,0	198,0	-	-	-	193,0
50	56,0	197,0	-	-	-	192,5
54	48,5	194,0	-	-	-	191,5
58	42,0	190,0	-	-	-	190,5
62	36,0	185,0	-	-	-	189,5
66	31,0	180,0	-	-	-	187,5
70	26,0	175,0	-	-	-	185,0
74	22,0	170,0	-	-	-	182,5
76	20,0	167,0	-	-	-	181,0
78	-	160,0	187,0	-	-	179,5
82	-	144,0	187,0	-	-	174,0
86	-	129,0	184,0	-	-	165,5
90	-	115,5	174,0	-	-	158,0
94	-	103,0	159,0	-	-	151,0
98	-	90,7	145,0	-	-	145,5
100	-	84,5	139,0	-	-	143,0
102	-	-	134,0	-	-	139,0
106	-	-	122,0	128,0	-	129,0
110	-	-	109,0	128,0	-	117,0
114	-	-	97,5	125,0	-	105,2
118	-	-	85,0	120,0	-	94,2
122	-	-	-	113,0	-	85,2
126	-	-	-	107,0	-	76,7
130	-	-	-	101,0	77,5	67,5
132	-	-	-	95,0	75,5	63,0
134	-	-	-	-	73,0	58,5
138	-	-	-	-	69,0	50,0
142	-	-	-	-	65,0	42,2
146	-	-	-	-	61,5	34,7
150	-	-	-	-	-	29,5
154	-	-	-	-	-	23,7
156	-	-	-	-	-	20,5

90 m + 108 m

m	SWSL					SFSL
	0 t		0 t-800 t			
	85°	85°	75°	65°	55°	t
40	-	152,0*	-	-	-	-
42	-	152,0*	-	-	-	-
46	-	149,0*	-	-	-	-
50	48,5	154,0	-	-	-	-
52	45,0	154,0	-	-	-	149,0
54	41,5	153,0	-	-	-	149,0
58	35,5	150,0	-	-	-	148,0
62	29,5	146,0	-	-	-	146,0
66	24,5	143,0	-	-	-	144,5
70	20,0	139,0	-	-	-	142,5
74	-	136,0	-	-	-	139,5
78	-	132,0	-	-	-	137,0
82	-	129,0	-	-	-	134,5
84	-	127,0	140,0	-	-	133,0
86	-	125,5	140,0	-	-	131,0
90	-	119,5	140,0	-	-	127,0
94	-	109,0	138,0	-	-	122,5
98	-	97,7	136,0	-	-	118,5
102	-	87,5	133,0	-	-	115,0
106	-	77,7	122,0	-	-	111,5
110	-	68,0	112,0	-	-	108,0
112	-	63,0	108,0	-	-	106,0
114	-	-	103,0	109,0	-	104,5
118	-	-	93,0	109,0	-	98,5
122	-	-	83,5	107,0	-	89,5
126	-	-	74,0	103,0	-	80,5
128	-	-	69,0	100,0	-	76,0
130	-	-	-	97,5	-	72,0
134	-	-	-	92,5	-	63,7
138	-	-	-	86,5	-	55,7
140	-	-	-	82,0	62,0	52,0
142	-	-	-	77,5	60,0	48,0
144	-	-	-	73,0	58,0	44,0
146	-	-	-	-	56,0	40,2
150	-	-	-	-	52,5	32,7
154	-	-	-	-	49,5	25,7
156	-	-	-	-	48,0	23,0
158	-	-	-	-	46,5	-
162	-	-	-	-	-	-

Remarks · Bemerkungen · Remarques

Main boom angle 88°, 85°, 75°, 65° and 55°; capacities for intermediate boom positions are calculated by the crane control system IC-1

Hauptauslegerwinkel 88°, 85°, 75°, 65° und 55°; Traglasten für Zwischenstellungen des Hauptauslegers werden von der Kransteuerung IC-1 berechnet

Jarret de flèche principale 88°, 85°, 75°, 65° et 55°; le système de commande de la grue IC-1 calcule les charges pour les positions intermédiaires de la flèche

* Main boom angle 88° · Hauptauslegerwinkel 88° · Jarret de flèche principale 88°





SWSL / SFSL 15° LIFTING CAPACITIES · TRAGFÄHIGKEITEN · CAPACITÉS DE LEVAGE

295 t + 60 t ZB 19-30 m 10,50 m 360° ISO

90 m + 120 m

m	SWSL					SFSL
	0 t		0 t-800 t			
	85°	85°	75°	65°	55°	t
44	-	115,0*	-	-	-	-
46	-	115,0*	-	-	-	-
50	-	113,0*	-	-	-	-
54	-	110,0*	-	-	-	-
56	31,5	114,0	-	-	-	112,0
58	28,5	114,0	-	-	-	112,0
62	23,0	112,0	-	-	-	111,0
64	20,5	110,0	-	-	-	110,0
66	-	109,0	-	-	-	109,0
70	-	106,0	-	-	-	107,5
74	-	104,0	-	-	-	105,5
78	-	99,5	-	-	-	103,0
82	-	95,0	-	-	-	101,0
86	-	90,7	-	-	-	99,0
90	-	86,2	100,0	-	-	96,7
94	-	81,7	100,0	-	-	93,7
98	-	77,2	98,0	-	-	90,7
102	-	72,7	94,0	-	-	88,2
106	-	68,2	90,0	-	-	85,5
110	-	63,7	85,0	-	-	82,7
114	-	59,2	80,0	-	-	80,5
118	-	54,0	75,0	-	-	78,5
122	-	47,2	70,0	79,0	-	76,2
124	-	43,5	68,0	79,0	-	75,0
126	-	-	65,5	79,0	-	73,7
130	-	-	61,5	76,0	-	70,2
134	-	-	57,5	72,0	-	64,0
138	-	-	53,0	68,0	-	56,0
140	-	-	49,0	65,5	-	52,0
142	-	-	-	64,0	-	49,0
146	-	-	-	60,0	-	42,5
150	-	-	-	56,0	45,5	35,5
154	-	-	-	52,0	42,5	28,7
156	-	-	-	-	41,0	25,5
158	-	-	-	-	39,5	-
162	-	-	-	-	36,5	-
166	-	-	-	-	33,7	-
168	-	-	-	-	32,5	-
170	-	-	-	-	-	-

96 m + 48 m

m	SWSL					SFSL
	0 t		0 t-800 t			
	85°	85°	75°	65°	55°	t
24	-	386,0*	-	-	-	-
26	-	377,0*	-	-	-	-
28	-	367,0*	-	-	-	-
30	153,0	403,0	-	-	-	395,0
34	133,0	396,0	-	-	-	394,0
38	118,0	382,0	-	-	-	392,0
42	104,0	368,0	-	-	-	389,5
46	93,0	353,0	-	-	-	382,0
50	83,5	311,0	-	-	-	367,5
54	75,0	274,0	365,0	-	-	358,0
56	70,0	250,0	365,0	-	-	353,0
58	-	-	362,0	-	-	343,0
62	-	-	346,0	-	-	317,5
66	-	-	317,0	-	-	287,5
70	-	-	280,0	-	-	261,0
74	-	-	248,0	-	-	238,0
77	-	-	-	239,0	-	221,2
78	-	-	-	235,0	-	215,5
82	-	-	-	220,0	-	194,0
86	-	-	-	206,0	-	175,0
90	-	-	-	194,0	-	158,5
94	-	-	-	-	-	143,0
97	-	-	-	-	146,0	131,2
98	-	-	-	-	143,0	127,5
102	-	-	-	-	136,0	113,0
104	-	-	-	-	132,0	106,0
106	-	-	-	-	-	99,2
110	-	-	-	-	-	86,5
114	-	-	-	-	-	74,5
118	-	-	-	-	-	64,5
122	-	-	-	-	-	57,0
126	-	-	-	-	-	47,2
128	-	-	-	-	-	41,5

Remarks · Bemerkungen · Remarques

Main boom angle 88°, 85°, 75°, 65° and 55°; capacities for intermediate boom positions are calculated by the crane control system IC-1
 Hauptauslegerwinkel 88°, 85°, 75°, 65° und 55°; Traglasten für Zwischenstellungen des Hauptauslegers werden von der Kransteuerung IC-1 berechnet
 Jarret de flèche principale 88°, 85°, 75°, 65° et 55°; le système de commande de la grue IC-1 calcule les charges pour les positions intermédiaires de la flèche

* Main boom angle 88° · Hauptauslegerwinkel 88° · Jarret de flèche principale 88°





SWSL / SFSL 15° LIFTING CAPACITIES · TRAGFÄHIGKEITEN · CAPACITÉS DE LEVAGE

295 t + 60 t ZB 19-30 m 10,50 m 360° ISO

96 m + 60 m

m	SWSL					SFSL
	0 t		0 t-800 t			
	85°	85°	75°	65°	55°	t
28	-	318,0*	-	-	-	-
30	-	312,0*	-	-	-	-
34	-	298,0*	-	-	-	-
36	115,0	333,0	-	-	-	327,0
38	107,0	330,0	-	-	-	326,0
42	95,0	320,0	-	-	-	324,5
46	84,5	310,0	-	-	-	323,5
50	75,0	299,0	-	-	-	319,0
54	67,0	285,0	-	-	-	311,0
58	60,0	255,0	-	-	-	302,0
60	56,5	241,0	308,0	-	-	299,0
62	53,5	225,0	308,0	-	-	293,5
66	46,5	193,0	300,0	-	-	280,5
68	43,5	177,0	294,0	-	-	273,0
70	-	-	289,0	-	-	263,5
74	-	-	259,0	-	-	243,0
78	-	-	233,0	-	-	221,0
82	-	-	211,0	-	-	200,5
84	-	-	195,0	-	-	191,0
86	-	-	-	200,0	-	182,0
90	-	-	-	188,0	-	165,0
94	-	-	-	177,0	-	149,0
98	-	-	-	167,0	-	134,5
100	-	-	-	163,0	-	128,0
102	-	-	-	-	-	121,5
106	-	-	-	-	121,0	108,5
110	-	-	-	-	115,0	96,0
114	-	-	-	-	109,0	84,5
116	-	-	-	-	106,0	79,0
118	-	-	-	-	-	73,5
122	-	-	-	-	-	62,5
126	-	-	-	-	-	53,5
130	-	-	-	-	-	47,0
134	-	-	-	-	-	38,7
138	-	-	-	-	-	29,5
140	-	-	-	-	-	25,0
142	-	-	-	-	-	-

96 m + 72 m

m	SWSL					SFSL
	0 t		0 t-800 t			
	85°	85°	75°	65°	55°	t
30	-	264,0*	-	-	-	-
34	-	260,0*	-	-	-	-
38	-	250,0*	-	-	-	-
40	91,0	277,0	-	-	-	271,0
42	85,5	275,0	-	-	-	270,0
46	75,5	269,0	-	-	-	268,5
50	66,5	262,0	-	-	-	267,5
54	58,5	254,0	-	-	-	265,5
58	52,0	246,0	-	-	-	261,0
62	46,0	236,0	-	-	-	255,0
66	40,5	209,0	256,0	-	-	249,0
70	35,5	184,0	256,0	-	-	241,0
74	31,5	162,0	249,0	-	-	229,5
78	27,0	140,0	239,0	-	-	218,5
80	25,0	128,0	227,0	-	-	213,0
82	-	-	216,0	-	-	204,5
86	-	-	196,0	-	-	187,5
90	-	-	175,0	-	-	171,0
92	-	-	165,0	175,0	-	163,0
94	-	-	154,0	172,0	-	155,0
96	-	-	143,0	167,0	-	147,0
98	-	-	-	162,0	-	140,0
102	-	-	-	152,0	-	126,5
106	-	-	-	144,0	-	114,0
110	-	-	-	136,0	-	102,7
112	-	-	-	133,0	-	97,5
114	-	-	-	-	-	92,0
115	-	-	-	-	100,0	89,2
118	-	-	-	-	96,5	81,2
122	-	-	-	-	91,0	71,0
126	-	-	-	-	86,5	61,2
130	-	-	-	-	-	51,5
134	-	-	-	-	-	43,0
138	-	-	-	-	-	37,0
142	-	-	-	-	-	30,0
144	-	-	-	-	-	26,0
146	-	-	-	-	-	-

Remarks · Bemerkungen · Remarques

Main boom angle 88°, 85°, 75°, 65° and 55°; capacities for intermediate boom positions are calculated by the crane control system IC-1
 Hauptauslegerwinkel 88°, 85°, 75°, 65° und 55°; Traglasten für Zwischenstellungen des Hauptauslegers werden von der Kransteuerung IC-1 berechnet
 Jarret de fleche principale 88°, 85°, 75°, 65° et 55°; le système de commande de la grue IC-1 calcule les charges pour les positions intermédiaires de la fleche

* Main boom angle 88° · Hauptauslegerwinkel 88° · Jarret de fleche principale 88°





SWSL / SFSL 15° LIFTING CAPACITIES · TRAGFÄHIGKEITEN · CAPACITÉS DE LEVAGE

295 t + 60 t ZB 19-30 m 10,50 m 360° ISO

96 m + 84 m

96 m + 96 m

m	SWSL					SFSL
	0 t		0 t-800 t			
	85°	85°	75°	65°	55°	t
34	-	219,0*	-	-	-	-
38	-	214,0*	-	-	-	-
42	-	207,0*	-	-	-	-
44	71,0	228,0	-	-	-	222,0
46	66,5	227,0	-	-	-	221,5
50	58,0	223,0	-	-	-	220,5
54	50,5	218,0	-	-	-	219,5
58	44,0	213,0	-	-	-	219,0
62	38,0	208,0	-	-	-	217,0
66	33,0	202,0	-	-	-	213,0
70	28,5	195,0	-	-	-	209,5
72	26,0	185,0	216,0	-	-	208,0
74	24,0	174,0	216,0	-	-	205,0
78	20,5	156,0	214,0	-	-	197,0
82	-	138,5	209,0	-	-	188,0
86	-	122,0	197,0	-	-	179,5
90	-	105,7	180,0	-	-	171,0
92	-	97,5	172,0	-	-	167,0
94	-	-	164,0	-	-	160,0
98	-	-	149,0	-	-	146,0
100	-	-	141,0	152,0	-	139,0
102	-	-	133,0	148,0	-	132,5
106	-	-	117,0	140,0	-	120,0
108	-	-	109,0	136,0	-	114,0
110	-	-	-	132,0	-	108,0
114	-	-	-	125,0	-	97,0
118	-	-	-	118,0	-	87,2
122	-	-	-	112,0	-	77,5
124	-	-	-	109,0	-	72,5
126	-	-	-	-	81,0	68,0
130	-	-	-	-	76,0	59,0
134	-	-	-	-	72,0	50,0
138	-	-	-	-	68,0	41,5
142	-	-	-	-	-	33,5
146	-	-	-	-	-	27,5
148	-	-	-	-	-	24,5
150	-	-	-	-	-	-

m	SWSL					SFSL
	0 t		0 t-800 t			
	85°	85°	75°	65°	55°	t
38	-	179,0*	-	-	-	-
42	-	176,0*	-	-	-	-
46	-	171,0*	-	-	-	-
48	54,5	185,0	-	-	-	181,0
50	51,0	185,0	-	-	-	180,5
54	44,0	182,0	-	-	-	179,5
58	37,5	179,0	-	-	-	179,0
62	32,0	175,0	-	-	-	178,5
66	27,0	171,0	-	-	-	177,0
70	22,5	166,0	-	-	-	174,5
72	20,5	164,0	-	-	-	173,0
74	-	162,0	-	-	-	172,0
78	-	157,0	176,0	-	-	170,0
82	-	146,0	176,0	-	-	166,5
86	-	131,0	174,0	-	-	159,5
90	-	117,5	171,0	-	-	151,5
94	-	104,7	164,0	-	-	145,5
98	-	92,2	150,0	-	-	140,0
100	-	86,0	144,0	-	-	137,0
102	-	-	138,0	-	-	133,5
106	-	-	126,0	-	-	124,0
108	-	-	120,0	119,0	-	118,0
110	-	-	114,0	119,0	-	112,5
114	-	-	102,0	118,0	-	101,7
118	-	-	90,0	113,0	-	91,5
120	-	-	83,5	110,0	-	86,5
122	-	-	-	107,0	-	81,7
126	-	-	-	101,0	-	73,0
130	-	-	-	96,0	-	64,5
134	-	-	-	91,0	66,5	56,0
138	-	-	-	-	62,5	48,0
142	-	-	-	-	59,0	40,0
146	-	-	-	-	55,5	32,2
150	-	-	-	-	52,0	25,0
152	-	-	-	-	-	21,5
154	-	-	-	-	-	-
158	-	-	-	-	-	-

Remarks · Bemerkungen · Remarques

Main boom angle 88°, 85°, 75°, 65° and 55°; capacities for intermediate boom positions are calculated by the crane control system IC-1
 Hauptauslegerwinkel 88°, 85°, 75°, 65° und 55°; Traglasten für Zwischenstellungen des Hauptauslegers werden von der Kransteuerung IC-1 berechnet
 Jarret de fleche principale 88°, 85°, 75°, 65° et 55°; le système de commande de la grue IC-1 calcule les charges pour les positions intermédiaires de la fleche

* Main boom angle 88° · Hauptauslegerwinkel 88° · Jarret de fleche principale 88°





SWSL / SFSL 15° LIFTING CAPACITIES · TRAGFÄHIGKEITEN · CAPACITÉS DE LEVAGE

295 t + 60 t ZB 19-30 m 10,50 m 360° ISO

96 m + 108 m

m	SWSL					SFSL
	0 t		0 t-800 t			
	85°	85°	75°	65°	55°	t
42	-	143,0*	-	-	-	-
46	-	140,0*	-	-	-	-
50	-	137,0*	-	-	-	-
52	40,0	145,0	-	-	-	141,0
54	37,0	145,0	-	-	-	140,5
58	31,0	142,0	-	-	-	139,0
62	25,5	139,0	-	-	-	138,0
66	21,0	135,0	-	-	-	137,0
70	-	132,0	-	-	-	135,0
74	-	129,0	-	-	-	133,0
78	-	126,0	-	-	-	130,5
82	-	122,5	-	-	-	128,0
84	-	121,0	129,0	-	-	127,0
86	-	119,0	129,0	-	-	125,5
90	-	115,5	129,0	-	-	122,0
94	-	109,5	128,0	-	-	117,5
98	-	99,5	126,0	-	-	113,5
102	-	89,0	125,0	-	-	109,0
106	-	79,0	121,0	-	-	105,5
110	-	69,2	116,0	-	-	102,0
112	-	64,5	111,0	-	-	100,0
114	-	-	107,0	-	-	98,7
116	-	-	102,0	100,0	-	97,5
118	-	-	97,0	100,0	-	93,7
122	-	-	87,2	100,0	-	85,5
126	-	-	77,7	97,5	-	76,5
130	-	-	68,0	92,0	-	67,7
134	-	-	-	86,5	-	60,0
138	-	-	-	82,0	-	52,5
142	-	-	-	77,5	-	44,7
144	-	-	-	75,5	52,0	41,0
146	-	-	-	73,5	50,5	37,5
150	-	-	-	-	47,0	30,5
154	-	-	-	-	43,5	23,7
156	-	-	-	-	42,0	20,5
158	-	-	-	-	41,0	-
160	-	-	-	-	39,5	-
162	-	-	-	-	-	-
166	-	-	-	-	-	-

96 m + 120 m

m	SWSL					SFSL
	0 t		0 t-800 t			
	85°	85°	75°	65°	55°	t
44	-	109,0*	-	-	-	-
46	-	109,0*	-	-	-	-
50	-	107,0*	-	-	-	-
54	-	104,0*	-	-	-	-
56	27,0	108,0	-	-	-	106,0
58	24,0	108,0	-	-	-	105,5
60	21,5	107,0	-	-	-	105,0
62	-	106,0	-	-	-	104,5
66	-	104,0	-	-	-	103,5
70	-	101,0	-	-	-	102,0
74	-	99,0	-	-	-	100,2
78	-	95,5	-	-	-	98,2
82	-	91,5	-	-	-	96,2
86	-	87,5	-	-	-	94,2
90	-	83,7	95,5	-	-	92,0
94	-	80,0	95,5	-	-	89,7
98	-	76,0	95,0	-	-	87,2
102	-	71,7	92,5	-	-	84,7
106	-	67,2	89,5	-	-	82,2
110	-	63,0	85,5	-	-	79,7
114	-	58,7	80,0	-	-	77,5
118	-	54,2	75,5	-	-	75,5
122	-	48,2	71,0	-	-	73,7
124	-	44,5	68,5	76,5	-	73,0
126	-	-	66,5	76,5	-	72,0
130	-	-	62,0	76,5	-	67,7
134	-	-	58,0	73,5	-	60,5
138	-	-	54,0	69,5	-	52,7
142	-	-	48,0	65,5	-	46,0
146	-	-	-	61,5	-	39,2
150	-	-	-	58,0	-	32,2
152	-	-	-	56,0	38,0	29,0
154	-	-	-	54,0	36,5	26,0
156	-	-	-	52,2	35,0	23,0
158	-	-	-	50,5	33,5	-
162	-	-	-	-	30,7	-
166	-	-	-	-	28,2	-
170	-	-	-	-	26,0	-
172	-	-	-	-	25,0	-

Remarks · Bemerkungen · Remarques

Main boom angle 88°, 85°, 75°, 65° and 55°; capacities for intermediate boom positions are calculated by the crane control system IC-1
 Hauptauslegerwinkel 88°, 85°, 75°, 65° und 55°; Traglasten für Zwischenstellungen des Hauptauslegers werden von der Kransteuerung IC-1 berechnet
 Jarret de flèche principale 88°, 85°, 75°, 65° et 55°; le système de commande de la grue IC-1 calcule les charges pour les positions intermédiaires de la flèche

* Main boom angle 88° · Hauptauslegerwinkel 88° · Jarret de flèche principale 88°





SWSL / SFSL 15° LIFTING CAPACITIES · TRAGFÄHIGKEITEN · CAPACITÉS DE LEVAGE

295 t + 60 t ZB 19-30 m 10,50 m 360° ISO

102 m + 48 m

102 m + 60 m

m	SWSL					SFSL
	0 t		0 t-800 t			
	85°	85°	75°	65°	55°	t
24	-	355,0*	-	-	-	-
26	-	347,0*	-	-	-	-
28	-	339,0*	-	-	-	-
30	-	330,0*	-	-	-	-
32	135,0	370,0	-	-	-	362,0
34	126,0	364,0	-	-	-	361,0
38	111,0	351,0	-	-	-	360,0
42	98,5	339,0	-	-	-	358,5
46	88,0	326,0	-	-	-	353,5
50	78,5	313,0	-	-	-	344,5
54	70,5	278,0	-	-	-	334,5
56	66,5	256,0	333,0	-	-	331,0
58	62,5	230,0	333,0	-	-	324,0
62	-	-	323,0	-	-	307,0
66	-	-	310,0	-	-	283,0
70	-	-	292,0	-	-	256,5
74	-	-	260,0	-	-	232,5
76	-	-	242,0	-	-	221,0
78	-	-	-	-	-	210,5
79	-	-	-	221,0	-	205,2
82	-	-	-	211,0	-	190,0
86	-	-	-	197,0	-	171,0
90	-	-	-	186,0	-	154,0
92	-	-	-	180,0	-	146,0
94	-	-	-	-	-	139,0
98	-	-	-	-	-	124,5
101	-	-	-	-	129,0	113,7
102	-	-	-	-	127,0	110,5
106	-	-	-	-	120,0	97,7
108	-	-	-	-	117,0	91,5
110	-	-	-	-	-	85,5
114	-	-	-	-	-	73,7
118	-	-	-	-	-	62,5
122	-	-	-	-	-	53,0
126	-	-	-	-	-	46,0
130	-	-	-	-	-	37,2
132	-	-	-	-	-	32,5

m	SWSL					SFSL
	0 t		0 t-800 t			
	85°	85°	75°	65°	55°	t
28	-	294,0*	-	-	-	-
30	-	288,0*	-	-	-	-
34	-	276,0*	-	-	-	-
36	108,0	306,0	-	-	-	300,0
38	101,0	304,0	-	-	-	300,0
42	89,5	295,0	-	-	-	298,5
46	79,0	286,0	-	-	-	297,0
50	70,0	277,0	-	-	-	294,0
54	62,5	268,0	-	-	-	289,0
58	55,5	257,0	-	-	-	282,5
62	49,5	229,0	285,0	-	-	276,0
66	44,0	197,0	282,0	-	-	266,0
68	41,0	181,0	278,0	-	-	259,0
70	-	-	273,0	-	-	253,0
74	-	-	263,0	-	-	236,5
78	-	-	241,0	-	-	215,5
82	-	-	218,0	-	-	195,5
86	-	-	191,0	-	-	177,5
88	-	-	-	186,0	-	169,0
90	-	-	-	180,0	-	161,0
94	-	-	-	169,0	-	145,0
98	-	-	-	159,0	-	130,0
102	-	-	-	151,0	-	117,0
104	-	-	-	147,0	-	111,0
106	-	-	-	-	-	105,0
110	-	-	-	-	107,0	93,5
114	-	-	-	-	101,0	82,2
118	-	-	-	-	96,0	71,2
119	-	-	-	-	94,5	68,6
122	-	-	-	-	-	61,0
126	-	-	-	-	-	51,2
130	-	-	-	-	-	42,2
134	-	-	-	-	-	36,0
138	-	-	-	-	-	29,0
140	-	-	-	-	-	25,0
142	-	-	-	-	-	-
146	-	-	-	-	-	-

Remarks · Bemerkungen · Remarques

Main boom angle 88°, 85°, 75°, 65° and 55°; capacities for intermediate boom positions are calculated by the crane control system IC-1
 Hauptauslegerwinkel 88°, 85°, 75°, 65° und 55°; Traglasten für Zwischenstellungen des Hauptauslegers werden von der Kransteuerung IC-1 berechnet
 Jarret de fleche principale 88°, 85°, 75°, 65° et 55°; le système de commande de la grue IC-1 calcule les charges pour les positions intermédiaires de la fleche
 * Main boom angle 88° · Hauptauslegerwinkel 88° · Jarret de fleche principale 88°





SWSL / SFSL 15° LIFTING CAPACITIES · TRAGFÄHIGKEITEN · CAPACITÉS DE LEVAGE

295 t + 60 t ZB 19-30 m 10,50 m 360° ISO

102 m + 72 m

m	SWSL					SFSL
	0 t		0 t-800 t			
	85°	85°	75°	65°	55°	t
30	-	244,0*	-	-	-	-
34	-	240,0*	-	-	-	-
38	-	231,0*	-	-	-	-
40	85,0	255,0	-	-	-	250,0
42	79,5	254,0	-	-	-	249,5
46	70,0	248,0	-	-	-	248,5
50	61,5	242,0	-	-	-	247,5
54	54,0	235,0	-	-	-	246,0
58	47,5	228,0	-	-	-	242,5
62	42,0	221,0	-	-	-	237,5
66	37,0	212,0	-	-	-	232,5
68	34,5	199,0	239,0	-	-	231,0
70	32,0	187,0	239,0	-	-	227,0
74	28,0	164,0	234,0	-	-	218,0
78	24,0	142,0	227,0	-	-	207,5
80	22,5	131,0	224,0	-	-	202,0
82	-	-	220,0	-	-	196,5
86	-	-	203,0	-	-	182,0
90	-	-	184,0	-	-	165,5
94	-	-	162,0	-	-	150,5
96	-	-	151,0	159,0	-	143,0
98	-	-	140,0	154,0	-	136,0
102	-	-	-	145,0	-	122,5
106	-	-	-	137,0	-	110,0
110	-	-	-	129,0	-	99,2
114	-	-	-	122,0	-	89,0
118	-	-	-	-	-	78,5
119	-	-	-	-	88,0	76,0
122	-	-	-	-	84,0	68,5
126	-	-	-	-	79,5	58,7
130	-	-	-	-	75,0	49,5
134	-	-	-	-	-	40,7
138	-	-	-	-	-	32,5
142	-	-	-	-	-	26,0
144	-	-	-	-	-	23,0

102 m + 84 m

m	SWSL					SFSL
	0 t		0 t-800 t			
	85°	85°	75°	65°	55°	t
34	-	201,0*	-	-	-	-
38	-	198,0*	-	-	-	-
42	-	192,0*	-	-	-	-
44	65,5	210,0	-	-	-	206,0
46	61,0	210,0	-	-	-	205,5
50	53,0	206,0	-	-	-	204,5
54	46,0	201,0	-	-	-	203,5
58	40,0	197,0	-	-	-	202,5
62	34,5	192,0	-	-	-	200,5
66	29,5	187,0	-	-	-	197,5
70	25,0	182,0	-	-	-	195,0
74	21,0	177,0	197,0	-	-	192,0
78	-	158,0	196,0	-	-	186,0
82	-	140,5	192,0	-	-	178,0
86	-	124,0	187,0	-	-	170,0
90	-	107,7	182,0	-	-	162,5
92	-	99,5	177,0	-	-	159,0
94	-	-	170,0	-	-	153,5
98	-	-	155,0	-	-	141,5
102	-	-	139,0	-	-	128,0
104	-	-	131,0	128,0	-	121,0
106	-	-	123,0	128,0	-	115,5
110	-	-	107,0	125,0	-	104,2
114	-	-	-	118,0	-	93,5
118	-	-	-	111,0	-	83,2
122	-	-	-	105,0	-	74,0
126	-	-	-	100,0	-	65,5
128	-	-	-	-	72,0	61,0
130	-	-	-	-	69,5	56,5
134	-	-	-	-	65,5	47,7
138	-	-	-	-	61,5	39,5
142	-	-	-	-	58,0	31,7
146	-	-	-	-	-	24,0
148	-	-	-	-	-	20,0
150	-	-	-	-	-	-

Remarks · Bemerkungen · Remarques

Main boom angle 88°, 85°, 75°, 65° and 55°; capacities for intermediate boom positions are calculated by the crane control system IC-1
 Hauptauslegerwinkel 88°, 85°, 75°, 65° und 55°; Traglasten für Zwischenstellungen des Hauptauslegers werden von der Kransteuerung IC-1 berechnet
 Jarret de fleche principale 88°, 85°, 75°, 65° et 55°; le système de commande de la grue IC-1 calcule les charges pour les positions intermédiaires de la fleche

* Main boom angle 88° · Hauptauslegerwinkel 88° · Jarret de fleche principale 88°





SWSL / SFSL 15° LIFTING CAPACITIES · TRAGFÄHIGKEITEN · CAPACITÉS DE LEVAGE

295 t + 60 t ZB 19-30 m 10,50 m 360° ISO

102 m + 96 m

102 m + 108 m

m	SWSL					SFSL
	0 t - 800 t					
	85°	85°	75°	65°	55°	t
38	-	166,0*	-	-	-	-
42	-	163,0*	-	-	-	-
46	-	158,0*	-	-	-	-
48	50,0	172,0	-	-	-	167,0
50	46,0	172,0	-	-	-	167,0
54	39,5	169,0	-	-	-	166,5
58	33,5	166,0	-	-	-	165,5
62	28,0	163,0	-	-	-	164,5
66	23,5	159,0	-	-	-	164,0
68	21,0	157,0	-	-	-	164,0
70	-	155,0	-	-	-	162,5
74	-	152,0	-	-	-	160,0
78	-	148,0	-	-	-	157,5
80	-	146,0	163,0	-	-	156,0
82	-	143,0	163,0	-	-	155,0
86	-	133,0	162,0	-	-	150,5
90	-	119,0	160,0	-	-	143,5
94	-	106,0	157,0	-	-	137,5
98	-	93,7	153,0	-	-	131,5
102	-	81,2	142,0	-	-	126,0
104	-	75,0	136,0	-	-	123,0
106	-	-	130,0	-	-	118,5
110	-	-	118,0	110,0	-	108,0
114	-	-	106,0	110,0	-	97,2
118	-	-	94,5	107,0	-	87,5
120	-	-	88,5	104,0	-	82,5
122	-	-	-	101,0	-	78,0
126	-	-	-	95,5	-	69,0
130	-	-	-	90,0	-	60,7
134	-	-	-	85,5	-	53,0
138	-	-	-	81,0	56,5	45,2
142	-	-	-	-	52,5	37,5
146	-	-	-	-	49,0	30,0
148	-	-	-	-	47,5	26,5
150	-	-	-	-	46,0	-
152	-	-	-	-	44,5	-
154	-	-	-	-	-	-

m	SWSL					SFSL
	0 t - 800 t					
	85°	85°	75°	65°	55°	t
42	-	134,0*	-	-	-	-
46	-	131,0*	-	-	-	-
50	-	128,0*	-	-	-	-
52	35,5	134,0	-	-	-	133,0
54	32,5	134,0	-	-	-	132,0
58	26,5	132,0	-	-	-	131,0
62	21,5	129,0	-	-	-	130,0
66	-	126,0	-	-	-	128,5
70	-	122,0	-	-	-	127,5
74	-	119,0	-	-	-	126,0
78	-	116,0	-	-	-	124,0
82	-	113,0	-	-	-	122,0
86	-	109,5	123,0	-	-	119,5
90	-	106,5	123,0	-	-	116,5
94	-	103,5	122,0	-	-	112,5
98	-	98,7	121,0	-	-	108,0
102	-	90,2	120,0	-	-	103,5
106	-	80,2	117,0	-	-	99,2
110	-	70,5	115,0	-	-	96,0
112	-	65,5	113,0	-	-	94,5
114	-	-	110,0	-	-	92,7
118	-	-	100,0	92,5	-	88,7
122	-	-	90,7	92,5	-	82,0
126	-	-	81,2	91,0	-	73,0
130	-	-	71,7	86,0	-	64,2
132	-	-	67,0	83,5	-	60,0
134	-	-	-	81,0	-	56,2
138	-	-	-	76,5	-	49,0
142	-	-	-	72,0	-	42,0
146	-	-	-	68,0	44,5	34,7
148	-	-	-	66,0	42,5	31,0
150	-	-	-	-	41,0	27,7
152	-	-	-	-	39,5	24,5
154	-	-	-	-	38,0	-
158	-	-	-	-	35,0	-
162	-	-	-	-	32,7	-
164	-	-	-	-	31,5	-

Remarks · Bemerkungen · Remarques

Main boom angle 88°, 85°, 75°, 65° and 55°; capacities for intermediate boom positions are calculated by the crane control system IC-1
 Hauptauslegerwinkel 88°, 85°, 75°, 65° und 55°; Traglasten für Zwischenstellungen des Hauptauslegers werden von der Kransteuerung IC-1 berechnet
 Jarret de fleche principale 88°, 85°, 75°, 65° et 55°; le système de commande de la grue IC-1 calcule les charges pour les positions intermédiaires de la fleche

* Main boom angle 88° · Hauptauslegerwinkel 88° · Jarret de fleche principale 88°





SWSL / SFSL 15° LIFTING CAPACITIES · TRAGFÄHIGKEITEN · CAPACITÉS DE LEVAGE

295 t + 60 t ZB 19-30 m 10,50 m 360° ISO

102 m + 120 m

m	SWSL					SFSL
	0 t		0 t-800 t			
	85°	85°	75°	65°	55°	t
44	-	102,0*	-	-	-	-
46	-	102,0*	-	-	-	-
50	-	100,0*	-	-	-	-
54	-	97,5*	-	-	-	-
56	-	102,0	-	-	-	99,5
58	-	102,0	-	-	-	99,2
62	-	101,0	-	-	-	98,2
66	-	98,5	-	-	-	96,7
70	-	96,5	-	-	-	95,7
74	-	94,0	-	-	-	94,7
78	-	90,5	-	-	-	93,2
82	-	87,2	-	-	-	91,5
86	-	84,0	-	-	-	89,5
90	-	80,7	-	-	-	87,7
92	-	79,0	91,0	-	-	87,0
94	-	77,2	91,0	-	-	85,7
98	-	73,7	90,5	-	-	83,0
102	-	70,0	90,0	-	-	80,2
106	-	66,0	88,0	-	-	77,5
110	-	62,0	84,5	-	-	75,0
114	-	58,0	80,5	-	-	73,0
118	-	54,0	76,0	-	-	70,7
122	-	48,5	71,5	-	-	68,5
124	-	45,0	69,5	-	-	67,5
126	-	-	67,5	73,5	-	66,5
130	-	-	63,0	73,5	-	63,0
134	-	-	59,5	73,0	-	56,7
138	-	-	55,5	69,5	-	49,2
142	-	-	51,0	65,0	-	42,0
144	-	-	47,0	63,0	-	38,5
146	-	-	-	61,0	-	35,5
150	-	-	-	57,5	-	29,2
152	-	-	-	55,7	-	26,0
154	-	-	-	54,0	-	-
156	-	-	-	52,2	29,5	-
158	-	-	-	50,5	28,0	-
162	-	-	-	-	25,2	-
166	-	-	-	-	22,7	-
168	-	-	-	-	21,5	-

108 m + 48 m

m	SWSL					SFSL
	0 t		0 t-800 t			
	85°	85°	75°	65°	55°	t
24	-	324,0*	-	-	-	-
26	-	320,0*	-	-	-	-
28	-	313,0*	-	-	-	-
30	-	305,0*	-	-	-	-
32	127,0	338,0	-	-	-	332,0
34	118,0	335,0	-	-	-	331,0
38	104,0	323,0	-	-	-	330,0
42	92,0	311,0	-	-	-	328,5
46	82,0	300,0	-	-	-	325,0
50	73,0	288,0	-	-	-	317,5
54	65,5	278,0	-	-	-	309,0
58	58,5	237,0	310,0	-	-	298,5
62	-	-	305,0	-	-	287,0
66	-	-	293,0	-	-	271,5
70	-	-	282,0	-	-	250,0
74	-	-	263,0	-	-	225,0
76	-	-	255,0	-	-	213,0
78	-	-	-	-	-	203,0
82	-	-	-	200,0	-	183,0
86	-	-	-	187,0	-	164,5
90	-	-	-	176,0	-	148,0
94	-	-	-	166,0	-	133,0
98	-	-	-	-	-	119,5
102	-	-	-	-	-	106,5
104	-	-	-	-	114,0	100,0
106	-	-	-	-	111,0	94,0
110	-	-	-	-	105,0	82,2
111	-	-	-	-	103,0	79,3
114	-	-	-	-	-	70,7
118	-	-	-	-	-	59,7
122	-	-	-	-	-	49,5
126	-	-	-	-	-	39,5
130	-	-	-	-	-	33,2
134	-	-	-	-	-	26,0
136	-	-	-	-	-	21,5

Remarks · Bemerkungen · Remarques

Main boom angle 88°, 85°, 75°, 65° and 55°; capacities for intermediate boom positions are calculated by the crane control system IC-1
 Hauptauslegerwinkel 88°, 85°, 75°, 65° und 55°; Traglasten für Zwischenstellungen des Hauptauslegers werden von der Kransteuerung IC-1 berechnet
 Jarret de flèche principale 88°, 85°, 75°, 65° et 55°; le système de commande de la grue IC-1 calcule les charges pour les positions intermédiaires de la flèche

* Main boom angle 88° · Hauptauslegerwinkel 88° · Jarret de flèche principale 88°





SWSL / SFSL 15° LIFTING CAPACITIES · TRAGFÄHIGKEITEN · CAPACITÉS DE LEVAGE

295 t + 60 t ZB 19-30 m 10,50 m 360° ISO

108 m + 60 m

108 m + 72 m

m	SWSL					SFSL
	0 t		0 t-800 t			
	85°	85°	75°	65°	55°	t
28	-	271,0*	-	-	-	-
30	-	266,0*	-	-	-	-
34	-	255,0*	-	-	-	-
36	101,0	282,0	-	-	-	276,0
38	94,5	279,0	-	-	-	275,0
42	83,0	271,0	-	-	-	274,0
46	73,0	263,0	-	-	-	272,5
50	65,0	254,0	-	-	-	271,0
54	57,5	245,0	-	-	-	267,0
58	51,0	237,0	-	-	-	261,5
62	45,5	227,0	-	-	-	255,0
64	42,5	217,0	260,0	-	-	251,0
66	40,5	201,0	260,0	-	-	245,0
70	35,5	169,0	251,0	-	-	234,0
74	-	-	243,0	-	-	222,0
78	-	-	235,0	-	-	207,0
82	-	-	226,0	-	-	188,5
86	-	-	203,0	-	-	170,5
88	-	-	187,0	-	-	162,0
90	-	-	-	170,0	-	154,5
94	-	-	-	160,0	-	139,0
98	-	-	-	150,0	-	124,5
102	-	-	-	142,0	-	112,0
106	-	-	-	134,0	-	100,5
110	-	-	-	-	-	89,2
113	-	-	-	-	93,5	80,8
114	-	-	-	-	92,0	78,2
118	-	-	-	-	87,0	67,7
122	-	-	-	-	82,5	57,7
126	-	-	-	-	-	48,2
130	-	-	-	-	-	39,2
134	-	-	-	-	-	30,2
138	-	-	-	-	-	23,2
140	-	-	-	-	-	20,5
142	-	-	-	-	-	-

m	SWSL					SFSL
	0 t		0 t-800 t			
	85°	85°	75°	65°	55°	t
30	-	225,0*	-	-	-	-
34	-	221,0*	-	-	-	-
38	-	213,0*	-	-	-	-
40	78,5	234,0	-	-	-	229,0
42	73,5	234,0	-	-	-	228,5
46	64,0	228,0	-	-	-	228,0
50	56,0	222,0	-	-	-	227,5
54	49,5	216,0	-	-	-	226,5
58	43,0	210,0	-	-	-	224,0
62	37,5	203,0	-	-	-	220,0
66	32,5	197,0	-	-	-	215,5
70	28,5	189,0	220,0	-	-	211,0
74	24,5	167,0	218,0	-	-	203,5
78	20,5	145,0	213,0	-	-	194,5
80	-	134,0	210,0	-	-	190,0
82	-	-	206,0	-	-	185,0
86	-	-	200,0	-	-	173,5
90	-	-	191,0	-	-	159,0
94	-	-	170,0	-	-	143,5
98	-	-	148,0	145,0	-	129,5
100	-	-	137,0	141,0	-	123,0
102	-	-	-	136,0	-	116,5
106	-	-	-	128,0	-	104,5
110	-	-	-	121,0	-	93,7
114	-	-	-	114,0	-	83,7
118	-	-	-	109,0	-	74,0
122	-	-	-	-	75,5	64,5
126	-	-	-	-	71,0	55,2
130	-	-	-	-	67,0	46,2
134	-	-	-	-	63,5	37,7
138	-	-	-	-	-	29,2
140	-	-	-	-	-	25,0
142	-	-	-	-	-	-
146	-	-	-	-	-	-
150	-	-	-	-	-	-

Remarks · Bemerkungen · Remarques

Main boom angle 88°, 85°, 75°, 65° and 55°; capacities for intermediate boom positions are calculated by the crane control system IC-1
 Hauptauslegerwinkel 88°, 85°, 75°, 65° und 55°; Traglasten für Zwischenstellungen des Hauptauslegers werden von der Kransteuerung IC-1 berechnet
 Jarret de fleche principale 88°, 85°, 75°, 65° et 55°; le système de commande de la grue IC-1 calcule les charges pour les positions intermédiaires de la fleche

* Main boom angle 88° · Hauptauslegerwinkel 88° · Jarret de fleche principale 88°





SWSL / SFSL 15° LIFTING CAPACITIES · TRAGFÄHIGKEITEN · CAPACITÉS DE LEVAGE

295 t + 60 t ZB 19-30 m 10,50 m 360° ISO

108 m + 84 m

m	SWSL					SFSL
	0 t		0 t-800 t			
	85°	85°	75°	65°	55°	t
34	-	186,0*	-	-	-	-
38	-	183,0*	-	-	-	-
42	-	177,0*	-	-	-	-
44	59,5	194,0	-	-	-	189,0
46	55,5	194,0	-	-	-	188,5
50	48,0	189,0	-	-	-	187,5
54	41,0	185,0	-	-	-	187,0
58	35,5	181,0	-	-	-	186,5
62	30,0	176,0	-	-	-	185,0
66	25,5	172,0	-	-	-	182,5
70	21,0	167,0	-	-	-	179,5
74	-	162,0	-	-	-	177,0
76	-	159,0	182,0	-	-	176,0
78	-	156,0	182,0	-	-	174,0
82	-	142,5	179,0	-	-	165,5
86	-	126,0	175,0	-	-	158,5
90	-	109,5	170,0	-	-	151,5
92	-	101,0	168,0	-	-	148,0
94	-	-	166,0	-	-	144,5
98	-	-	160,0	-	-	135,0
102	-	-	145,0	-	-	122,5
106	-	-	129,0	118,0	-	110,5
110	-	-	113,0	117,0	-	99,2
114	-	-	-	110,0	-	88,5
118	-	-	-	104,0	-	78,5
122	-	-	-	98,5	-	69,5
126	-	-	-	93,0	-	61,2
128	-	-	-	90,5	-	57,0
130	-	-	-	-	-	52,7
132	-	-	-	-	59,5	48,5
134	-	-	-	-	58,0	44,2
138	-	-	-	-	54,0	36,2
142	-	-	-	-	50,5	28,5
144	-	-	-	-	49,0	24,5
146	-	-	-	-	-	-
150	-	-	-	-	-	-
154	-	-	-	-	-	-

108 m + 96 m

m	SWSL					SFSL
	0 t		0 t-800 t			
	85°	85°	75°	65°	55°	t
38	-	152,0*	-	-	-	-
42	-	150,0*	-	-	-	-
46	-	146,0*	-	-	-	-
48	44,5	158,0	-	-	-	155,0
50	40,5	158,0	-	-	-	154,5
54	34,5	156,0	-	-	-	153,5
58	28,5	153,0	-	-	-	153,0
62	23,5	149,0	-	-	-	152,5
64	21,5	148,0	-	-	-	152,0
66	-	146,0	-	-	-	151,0
70	-	143,0	-	-	-	149,0
74	-	140,0	-	-	-	147,5
78	-	136,0	-	-	-	145,5
82	-	133,0	151,0	-	-	143,0
86	-	128,5	150,0	-	-	140,0
90	-	120,0	148,0	-	-	134,5
94	-	107,5	146,0	-	-	126,5
98	-	95,0	143,0	-	-	121,0
102	-	82,7	139,0	-	-	115,5
104	-	76,5	137,0	-	-	113,0
106	-	-	134,0	-	-	110,5
110	-	-	123,0	-	-	102,7
114	-	-	111,0	101,0	-	92,2
118	-	-	99,0	99,5	-	82,2
122	-	-	87,0	93,5	-	73,0
126	-	-	-	88,0	-	64,2
130	-	-	-	83,0	-	55,7
134	-	-	-	78,5	-	48,2
138	-	-	-	74,0	-	41,2
140	-	-	-	72,0	-	37,5
142	-	-	-	-	45,5	33,7
146	-	-	-	-	42,0	26,5
148	-	-	-	-	40,5	23,0
150	-	-	-	-	39,0	-
154	-	-	-	-	36,5	-
156	-	-	-	-	35,0	-
158	-	-	-	-	-	-

Remarks · Bemerkungen · Remarques

Main boom angle 88°, 85°, 75°, 65° and 55°; capacities for intermediate boom positions are calculated by the crane control system IC-1

Hauptauslegerwinkel 88°, 85°, 75°, 65° und 55°; Traglasten für Zwischenstellungen des Hauptauslegers werden von der Kransteuerung IC-1 berechnet

Jarret de fleche principale 88°, 85°, 75°, 65° et 55°; le système de commande de la grue IC-1 calcule les charges pour les positions intermédiaires de la fleche

* Main boom angle 88° · Hauptauslegerwinkel 88° · Jarret de fleche principale 88°





SWSL / SFSL 15° LIFTING CAPACITIES · TRAGFÄHIGKEITEN · CAPACITÉS DE LEVAGE

295 t + 60 t ZB 19-30 m 10,50 m 360° ISO

108 m + 108 m

108 m + 120 m

m	SWSL					SFSL
	0 t		0 t-800 t			
	85°	85°	75°	65°	55°	t
42	-	122,0*	-	-	-	-
46	-	121,0*	-	-	-	-
50	-	118,0*	-	-	-	-
52	30,5	126,0	-	-	-	123,0
54	27,5	126,0	-	-	-	122,5
58	22,0	124,0	-	-	-	122,0
62	-	121,0	-	-	-	121,0
66	-	118,0	-	-	-	120,0
70	-	115,0	-	-	-	119,5
74	-	112,0	-	-	-	117,5
78	-	109,0	-	-	-	115,5
82	-	106,5	-	-	-	114,0
86	-	103,5	-	-	-	112,0
88	-	102,0	116,0	-	-	111,0
90	-	100,5	116,0	-	-	110,0
94	-	97,5	116,0	-	-	107,0
98	-	94,5	115,0	-	-	102,5
102	-	89,7	113,0	-	-	98,0
106	-	81,5	112,0	-	-	93,2
110	-	71,5	110,0	-	-	90,0
114	-	61,5	108,0	-	-	86,7
116	-	56,5	106,0	-	-	85,0
118	-	-	104,0	-	-	83,0
122	-	-	94,5	83,5	-	76,7
126	-	-	84,7	83,5	-	68,0
130	-	-	75,5	79,0	-	59,5
134	-	-	65,5	74,0	-	51,7
138	-	-	-	69,5	-	44,2
142	-	-	-	65,5	-	37,5
146	-	-	-	61,5	-	31,0
150	-	-	-	58,0	34,0	24,2
152	-	-	-	-	32,5	21,0
154	-	-	-	-	31,0	-
158	-	-	-	-	28,5	-
162	-	-	-	-	25,7	-
166	-	-	-	-	23,5	-
168	-	-	-	-	22,5	-

m	SWSL					SFSL
	0 t		0 t-800 t			
	85°	85°	75°	65°	55°	t
46	-	95,0*	-	-	-	-
50	-	93,0*	-	-	-	-
54	-	90,5*	-	-	-	-
56	-	95,5	-	-	-	93,0
58	-	95,5	-	-	-	92,7
62	-	94,5	-	-	-	92,0
66	-	92,5	-	-	-	91,0
70	-	90,0	-	-	-	89,7
74	-	88,0	-	-	-	88,5
78	-	85,5	-	-	-	87,2
82	-	83,0	-	-	-	85,5
86	-	80,0	-	-	-	83,7
90	-	77,0	-	-	-	82,0
94	-	74,2	86,0	-	-	80,2
98	-	71,2	86,0	-	-	78,5
102	-	67,7	85,5	-	-	76,0
106	-	64,0	84,0	-	-	73,0
110	-	60,2	82,5	-	-	70,0
114	-	56,7	80,0	-	-	67,5
118	-	53,0	76,0	-	-	65,2
122	-	48,5	72,0	-	-	62,7
124	-	46,0	70,0	-	-	61,5
126	-	-	68,0	-	-	60,5
128	-	-	66,0	67,0	-	59,5
130	-	-	64,0	67,0	-	57,5
134	-	-	60,0	67,0	-	52,0
138	-	-	56,5	63,0	-	44,7
142	-	-	52,5	58,5	-	37,5
146	-	-	46,0	55,0	-	30,7
150	-	-	-	51,0	-	24,7
152	-	-	-	49,2	-	22,0
154	-	-	-	47,5	-	-
158	-	-	-	44,5	-	-
162	-	-	-	41,5	-	-
166	-	-	-	-	-	-
170	-	-	-	-	-	-
174	-	-	-	-	-	-

Remarks · Bemerkungen · Remarques

Main boom angle 88°, 85°, 75°, 65° and 55°; capacities for intermediate boom positions are calculated by the crane control system IC-1
 Hauptauslegerwinkel 88°, 85°, 75°, 65° und 55°; Traglasten für Zwischenstellungen des Hauptauslegers werden von der Kransteuerung IC-1 berechnet
 Jarret de fleche principale 88°, 85°, 75°, 65° et 55°; le système de commande de la grue IC-1 calcule les charges pour les positions intermédiaires de la fleche

* Main boom angle 88° · Hauptauslegerwinkel 88° · Jarret de fleche principale 88°





SFVL WORKING RANGES · ARBEITSBEREICHE · PORTÉES

15°

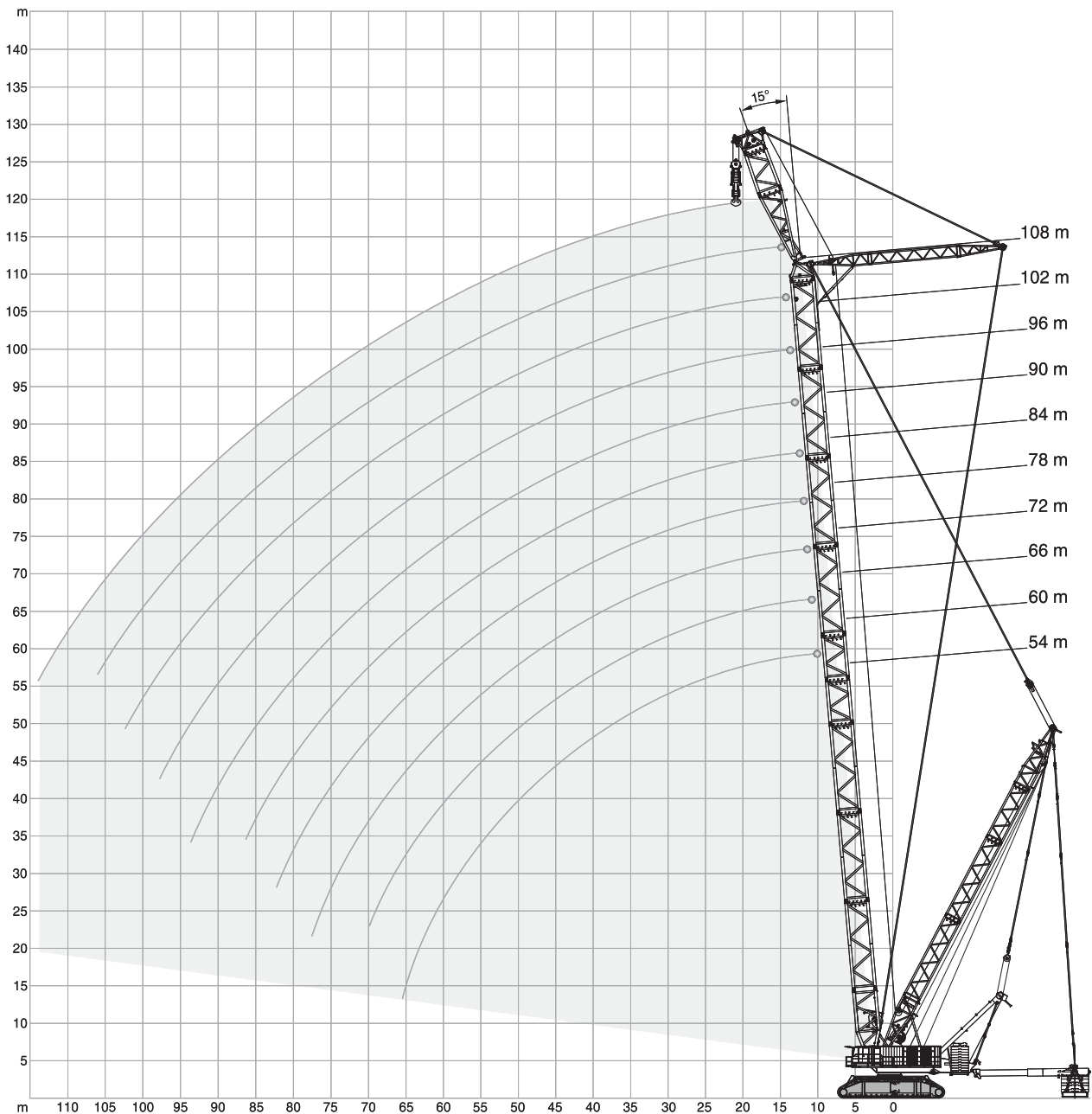



SFVL LIFTING CAPACITIES · TRAGFÄHIGKEITEN · CAPACITÉS DE LEVAGE

295 t + 60 t ZB 19-30 m 18 m 15° 0-800 t 10,50 m 360° ISO

	54 m	60 m	66 m	72 m	78 m	84 m	90 m	96 m	102 m	108 m	
m	t	t	t	t	t	t	t	t	t	t	m
18	1018,0	992,0	972,0	924,0	-	-	-	-	-	-	18
20	958,0	940,0	924,0	911,0	862,0	798,0	718,0	654,0	-	-	20
22	905,0	892,0	882,0	876,0	846,0	794,0	718,0	654,0	595,0	542,0	22
24	857,0	849,0	843,0	840,0	829,0	793,0	718,0	654,0	595,0	542,0	24
26	815,0	811,0	807,0	807,0	804,0	791,0	718,0	654,0	595,0	542,0	26
28	776,0	776,0	775,0	777,0	776,0	783,0	718,0	654,0	595,0	542,0	28
30	742,0	744,0	745,0	749,0	750,0	761,0	714,0	654,0	595,0	542,0	30
34	681,0	687,0	693,0	699,0	703,0	714,0	667,0	620,0	582,0	536,0	34
38	625,0	640,0	640,0	635,0	630,0	626,0	625,0	596,0	554,0	519,0	38
42	537,0	566,0	569,0	564,0	558,0	555,0	553,0	547,0	535,0	500,0	42
46	464,0	492,0	510,0	505,0	499,0	496,0	494,0	488,0	484,0	479,0	46
50	411,0	432,0	448,0	456,0	450,0	446,0	444,0	438,0	434,0	431,0	50
54	367,0	377,0	396,0	406,0	408,0	404,0	402,0	396,0	391,0	389,0	54
58	319,0	335,0	349,0	362,0	367,0	367,0	365,0	359,0	355,0	352,0	58
62	276,0	302,0	307,0	321,0	329,0	331,0	334,0	328,0	323,0	320,0	62
66	235,0	263,0	276,0	284,0	293,0	298,0	304,0	300,0	295,0	292,0	66
70	-	227,0	248,0	250,0	260,0	266,0	273,0	272,0	268,0	266,0	70
74	-	-	215,0	228,0	230,0	237,0	245,0	245,0	243,0	241,0	74
78	-	-	184,0	202,0	205,0	211,0	219,0	220,0	219,0	219,0	78
82	-	-	-	174,0	188,0	186,0	195,0	197,0	197,0	198,0	82
86	-	-	-	-	163,0	170,0	172,0	175,0	176,0	177,0	86
90	-	-	-	-	-	151,0	154,0	155,0	157,0	159,0	90
94	-	-	-	-	-	129,0	141,0	136,0	139,0	141,0	94
98	-	-	-	-	-	-	121,0	125,0	121,0	124,0	98
102	-	-	-	-	-	-	-	109,0	110,0	109,0	102
106	-	-	-	-	-	-	-	-	97,5	97,5	106
110	-	-	-	-	-	-	-	-	-	87,0	110
114	-	-	-	-	-	-	-	-	-	72,5	114
118	-	-	-	-	-	-	-	-	-	-	118





TECHNICAL DESCRIPTION

CRAWLER CARRIER

	5-section carrier comprising carbody, two cross axles and two split-type crawler side frames. Carbody, cross axles and side frames are pin-connected hydraulically. Track width: 10.5 m.
Carbody	Bending- and torsion-resistant welded structure fabricated from high-strength fine grain structural steel. Quick-disconnect fittings (optional) facilitate removal of slew ring from carbody to minimise weight for transportation.
Cross axles	Bending- and torsion-resistant welded structure fabricated from high-strength fine grain structural steel incl. hydraulic jack legs.
Crawler side frames	Bending- and torsion-resistant welded structure fabricated from high-strength fine grain structural steel. Split-type side frames to minimise weight for transportation. Centralised lubrication included as standard.
Crawlers	Crawler pads made of heat-treated high-strength cast steel. 15 rollers per crawler with hardened rolling surfaces.
Drive	The crawlers are each driven by two hydraulic motors through closed planetary gear reduction units running in an oil bath, equipped with spring-loaded, hydraulically released holding brakes. Each crawler provides independent, infinitely variable control and counter-rotation capability. Quadro-Drive as standard.
Slew unit	Four slew gearboxes in carbody powered by hydraulic motors through closed planetary gear units running in oil bath. Spring-applied, hydraulically released holding brake and non-wearing hydraulic braking.

SUPERSTRUCTURE

Counterweight	295 t in combination with 60 t central ballast.
Frame	Torsion-resistant welded structure fabricated from high-strength fine grain structural steel. Longitudinal beam construction to accommodate three rope drums and boom hoist. Split-type superstructure for ease of transportation.
Power and control module	Two independent drive units incl. pump distribution gearbox and pumps are contained in a separate module which is connected to the side of the superstructure. Power comes from a Daimler diesel engine type OM 502 LA. Output to DIN 70020: 380 kW (516 HP) at 2000 1/min, torque 2400 Nm at 1080 1/min. The engine complies with EUROMOT 3a, EPA T3 and Carb regulations. Pump distribution gearbox with five variable displacement axial piston pumps and gear pumps. The power and control module includes cabin, complete electrics and electric generators as standard. Fuel tank capacity: 2000 l.
Rope drums	Standard superstructure equipment includes three rope drums – hoist 1, hoist 2 and boom hoist. Rope drums powered through closed planetary gear units running in oil bath. All rope drums have hydraulically released multi-disc brakes and non-wearing hydraulic braking for load lowering. Rope ends of all drums provided with quick-connect rope end fittings. Hydraulically pinned hoists H1 and H2 (H3 optional) can be removed in order to minimise weight for transportation.
Control system	Demag IC-1: Electronic proportional valve pilot control integrated in stored-program control system incl. diagnostics. Two colour monitors, load indicator operated via a touchscreen. Working speeds infinitely variable controlled by the lever position. Automatic power control for optimal utilisation of engine output. Standard working range limitation and ground pressure indicator.
Cabin	Spacious comfortable cab located at front end of power module. Large laminated glass for front and roof windows, computerised airconditioner as standard and self-contained hot air heater. Front console includes instrumentation and crane controls as well as two graphic displays. It can be tilted back, together with the operator seat, for an improved operator view of the boom point. Camera systems for monitoring the rope drums and SL ballast, hourmeter, load moment indicator, 2 working lights, storage cabinets and refrigerator are included as standard.
Electrical equipment	24 V system (2 batteries 12 V / 180 Ah). 3-phase alternator 24 V, 80 A. plus 3-phase generator 400 V 50 Hz 20 kVA for airconditioner, heater, lighting and multiple use on the job site. Emergency generator 400 V 50 Hz 16 kVA.
Quick-connection	Hydraulic quick-disconnect fittings on superstructure and carrier as standard.

OPTIONAL EQUIPMENT

Counterweight carrier	The counterweight carrier with a max. total weight of 640 t is adjustable over a distance of 19 m to 25 m or 24 m to 30 m from the centre of rotation, and can be operated in the circular path $\pm 30^\circ$ tailing and parallel travel modes. Deadweight 130 t, strips down to three components for easy transport.
Superlift counterweights	
Further options on request!	



CC9800
 CRAWLER CRANE

TECHNICAL DESCRIPTION

BOOM CONFIGURATIONS

General	Tubular chord lattice structure fabricated from high-strength fine grain structural steel. Walkways on boom, jib and Superlift mast. Hydraulic pinning.
SSL	Main boom: foot section 10 m, inserts 6 m and 12 m, boom head 2 m with 2 sheave-sets. Superlift equipment. Main boom lengths: 54-108 m
SSL / LSL (SGL 108 m)	Main boom: foot section 10 m, inserts 6 m and 12 m (type 3629), tapered insert, extended by inserts 6 m and 12 m (type 3227), heavy-lift top 2 m with 1 sheave-set from main boom SSL. Superlift equipment. Main boom lengths: 114-156 m
SWSL	Main boom: same as SSL. Offset 88° to 55°. Luffing fly jib: foot section 10 m, insert 12 m (type 3629), tapered insert, inserts 6 m and 12 m, heavy-lift top 2 m with 1 sheave-set from main boom SSL. Superlift equipment. Main boom lengths: 60-108 m Jib lengths: 36-120 m
SFSL	same as SWSL. Offset fly jib 15°.
SFVL	Main boom: same as SSL. Fixed fly jib: foot section 10 m, tapered insert, heavy-lift top 2 m with 2 sheave-sets from main boom SSL. Superlift equipment. Main boom lengths: 60-108 m Jib length: 18 m Offset: 15°
+LF	Addition to: SSL/LSL. Fixed fly jib: foot section 9 m, jib top section 9 m. Main boom lengths: 114-144 m Jib length: 18 m Offset: 20°
Pinning of boom	Hydraulic assisted pinning of boom sections as standard.
Reeving winch	Mounted on superstructure as standard.
Operator aids	Electronic load indicator, hoist limit switch, limit switches for boom movements, hydraulic boom backstops, anemometer.

SUPERLIFT CONFIGURATIONS

Tele-SL	Mast 50 m (type 2621), counterweight tray 800 t or counterweight carrier for max. 640 t optional. Superlift radius infinitely variable during operation: 19 m to 25 m with a mast radius of 22 m and 24 m to 30 m with a mast radius of 26.4 m.
----------------	--

OPTIONAL EQUIPMENT

Runner 60 t	Approx. 3 m, mounts on boom head and heavy-lift top.
Hoist H3	Mounted on superstructure.





TECHNISCHE BESCHREIBUNG

RAUPENUNTERWAGEN

	Der Raupenunterwagen ist 5-teilig und besteht aus einem Mittelstück, zwei Querträgern und zwei geteilten Raupenträgern. Raupenträger, Mittelstück und Querträger werden hydraulisch verbolzt. Die Spurbreite beträgt 10,5 m.
Mittelstück	Biege- und verwindungssteife Schweißkonstruktion aus hochfestem Feinkornbaustahl. Die Rollendrehverbindung sitzt am Mittelstück und ist mit Schnellspannmutter (optional) auf einfache Weise zur Reduzierung des Transportgewichtes lösbar.
Querträger	Biege- und verwindungssteife Schweißkonstruktion aus hochfestem Feinkornbaustahl mit hydraulischer Abstützung.
Raupenträger	Biege- und verwindungssteife Schweißkonstruktion aus hochfestem Feinkornbaustahl. Geteilter Raupenträger zur Minimierung der Transportgewichte. Zentralschmieranlage serienmäßig.
Raupen	Bodenplatten der Raupenkettens aus vergütetem hochfesten Stahlguß. 15 Laufrollen je Raupe mit gehärteten Laufflächen.
Antrieb	Die Raupen werden von je zwei Hydromotoren über geschlossene, ölbadeschmierte Planetengetriebe mit federbelasteten, hydraulisch gelüfteten Haltebremsen angetrieben. Jede Seite ist stufenlos, einzeln und gegenläufig steuerbar. Quadro-Antrieb serienmäßig.
Drehwerk	Vier Drehwerke im Mittelstück mit Antrieb durch Hydromotor über geschlossenes, ölbadeschmierte Planetengetriebe. Federbelastete, hydraulisch gelüftete Haltebremse und verschleißfreie hydraulische Bremsung.

OBERWAGEN

Gegengewicht	295 t in Verbindung mit 60 t Zentralballast.
Rahmen	Verformungssteife Schweißkonstruktion aus hochfestem Feinkornbaustahl. Die Längsträgerkonstruktion dient der Aufnahme von drei Winden und dem Einziehwerk. Aus Transportgründen ist der Oberwagen geteilt ausgeführt.
Antriebsmodul	Zwei voneinander unabhängige Antriebseinheiten samt Pumpenverteiler und Pumpen sitzen in einem separaten Modul, das seitlich am Oberwagen angebaut wird. Antriebstyp: Daimler Dieselmotor Typ OM 502 LA. Leistung nach DIN 70020: 380 kW (516 PS) bei 2000 1/min, Drehmoment 2400 Nm bei 1080 1/min. Der Motor erfüllt die EUROMOT 3a, EPA T3 und Carb-Vorschriften. Pumpenverteilergetriebe mit fünf verstellbaren Axialkolbenpumpen und zusätzlichen Zahnradpumpen. Im Antriebsmodul sind serienmäßig die Kabine, die gesamte Elektrik sowie die Stromerzeuger integriert. Kraftstoffbehälter: 2000 l.
Seilwinden	Der Oberwagen ist serienmäßig mit drei Seilwinden – Hubwerk 1, Hubwerk 2 und Einziehwerk – ausgerüstet. Der Antrieb der Winden erfolgt über geschlossene, ölbadeschmierte Planetengetriebe. Alle Seilwinden sind mit, hydraulisch gelüfteten Lamellenbremsen und verschleißfreier hydraulischer Bremsung für den Senkvorgang ausgerüstet. Die Seilenden aller Winden sind mit Pressfitting und Taschen ausgestattet. Zur Reduzierung der Transportgewichte sind die hydraulisch verbolzten Winden H1 und H2 (optional H3) ausbaubar.
Steuerung	Demag IC-1: Elektronische Proportionalventilvorsteuerung integriert in eine speicherprogrammierte Steuerung mit Fehlerdiagnose. Zwei Farbbildschirme, Bedienung über Touchscreen. Die Arbeitsgeschwindigkeiten werden durch die Hebelstellung stufenlos geregelt. Leistungsregelung der Antriebe zur optimalen Ausnutzung der Motorleistung. Serienmäßig Arbeitsbereichsbegrenzung und Anzeige der Bodenpressung.
Kabine	Die geräumige Komfortkabine ist im vorderen Bereich des Antriebsmoduls angeordnet. Sie ist mit großzügiger Sicherheitsverglasung auch im Dachbereich, computergesteuerter Klimaanlage serienmäßig und motorunabhängiger Warmluftheizung ausgestattet. Steuer- und Kontrollelemente für die Kranfunktionen sowie zwei Grafik-Displays befinden sich in der Frontkonsole. Diese ist zur Sichtverbesserung gemeinsam mit dem Fahrersitz nach hinten neigbar. Kamerasysteme für die Überwachung von Winden und SL-Ballast, Betriebsstundenzähler, Lastmomentanzeige, 2 Arbeitsscheinwerfer, Ablageschränke und Kühlschränke serienmäßig.
Elektrische Anlage	24 V System (2 x Batterie 12 V / 180 Ah). 3-Phasen Wechselstromgenerator 24 V, 80 A. zusätzlich 3-Phasengenerator 400 V 50 Hz 20 KVA für Klimaanlage, Heizung, Beleuchtung und vielfältige Anwendungen auf der Baustelle. Notstromaggregat 400 V 50 Hz 16 KVA.
Schnellverbindung	Hydraulische Schnellverbindung Oberwagen / Unterwagen serienmäßig.

ZUSATZAUSRÜSTUNG

Gegengewichtswagen	Der Gegengewichtswagen mit max. 640 t Gesamtgewicht kann im Abstand von 19 m bis 25 m bzw. 24 m bis 30 m zur Drehmitte frei verstellbar und in den Fahrzuständen Drehen, Hinterherfahrt und Nachlauf $\pm 30^\circ$ betrieben werden. Eigengewicht 130 t, zum Transport in drei Komponenten zerlegbar.
Superlift-Gegengewichte	
Weitere Zusatzausrüstungen auf Anfrage!	



CC9800
 CRAWLER CRANE

TECHNISCHE BESCHREIBUNG

AUSLEGERVARIANTEN

Allgemein	Gitter-Rohrkonstruktion aus hochfestem Feinkornbaustahl. Begehungen auf Hauptausleger, Hilfsausleger und Superlift-Mast. Hydraulisch verbolzbare.
SSL	Hauptausleger: Fußstück 10 m, Zwischenstücke 6 m und 12 m, Anschlusskopf 2 m mit 2 Rollensätzen. Superlift-Einrichtung. Hauptauslegerlängen: 54-108 m
SSL / LSL (SGL 108 m)	Hauptausleger: Fußstück 10 m, Zwischenstücke 6 m und 12 m (Typ 3629), Reduzierstück, verlängert um Zwischenstücke 6 m und 12 m (Typ 3227), Schwerlastkopf 2 m mit 1 Rollensatz vom Hauptausleger SSL. Superlift-Einrichtung. Hauptauslegerlängen: 114-156 m
SWSL	Hauptausleger: wie SSL. Vorneigung 88° bis 55°. Wippbarer Hilfsausleger: Fußstück 10 m, Zwischenstück 12 m (Typ 3629), Reduzierstück, Zwischenstücke 6 m und 12 m, Schwerlastkopf 2 m mit 1 Rollensatz vom Hauptausleger SSL. Superlift-Einrichtung. Hauptauslegerlängen: 60-108 m Hilfsauslegerlängen: 36-120 m
SFSL	wie SWSL. Vorneigung des Hilfsauslegers 15°.
SFVL	Hauptausleger: wie SSL. Starrer Hilfsausleger: Fußstück 10 m, Reduzierstück, Schwerlastkopf 2 m mit 2 Rollensätzen vom Hauptausleger SSL. Superlift-Einrichtung. Hauptauslegerlängen: 60-108 m Hilfsauslegerlänge: 18 m Vorneigung: 15°
+LF	Zusätzlich zu: SSL/LSL. Starrer Hilfsausleger: Fußstück 9 m, Spitze 9 m. Hauptauslegerlängen: 114-144 m Hilfsauslegerlänge: 18 m Vorneigung: 20°
Auslegerverbolzung	Serienmäßig hydraulische verbolzbare Auslegerteile.
Einscherwinde	Serienmäßig am Oberwagen angebaut.
Sicherheitseinrichtungen	Elektronischer Lastmomentbegrenzer, Hubendschalter, Endschalter für Auslegerbewegungen, hydraulische Ausleger-Rückfallsicherungen, Windmesser.

SUPERLIFT-KONFIGURATIONEN

Tele-SL	Mast 50 m (Typ 2621), Gegengewichtstraverse 800 t oder optional Gegengewichtswagen mit max. 640 t. Superlift-Radius stufenlos im Betrieb verstellbar von 19 m bis 25 m bei Mastradius 22 m und von 24 m bis 30 m bei Mastradius 26,4 m.
----------------	--

ZUSATZAUSRÜSTUNG

Runner 60 t	ca. 3 m, anbaubar an Anschlusskopf und Schwerlastkopf.
Hubwerk H3	Wird im Oberwagen eingebaut.

6





DESCRIPTIF TECHNIQUE

CHÂSSIS À CHENILLES

	Le porteur à chenilles est réalisé en 5 parties et se compose d'une partie centrale, de deux traverses et de deux trains de chenilles divisibles en deux parties. Les trains de chenilles, la partie centrale et les traverses sont verrouillés hydrauliquement. La voie est de 10,5 m.
Partie centrale	Structure mécano-soudée rigide à la flexion et à la torsion, réalisée en acier de construction à grains fins à haute résistance. Ecrous à serrage rapide (en option) facilitant le démontage de la couronne d'orientation pour réduire les poids de transport.
Traverses	Structure mécano-soudée rigide à la flexion et à la torsion, réalisée en acier de construction à grains fins à haute résistance, avec calage hydraulique.
Trains de chenille	Structure mécano-soudée rigide à la flexion et à la torsion, réalisée en acier de construction à grains fins à haute résistance. Trains de chenilles divisibles pour minimiser les poids de transport. Graissage centralisé en série.
Chenilles	Patins de chenilles en acier coulé trempé et revenu à haute résistance. 15 galets par chenille avec surfaces de roulement trempées.
Entraînement	Les chenilles sont entraînées chacune par deux moteurs hydrauliques avec réducteurs planétaires en carter étanche sous bain d'huile, munis de freins d'arrêt à ressorts à desserrage hydraulique. Chaque côté permet un mouvement réglable sans paliers individuel et dans le sens opposé. Entraînement quadro en série.
Mécanisme d'orientation	Quatre mécanismes d'orientation dans la partie centrale entraînés par moteurs hydrauliques avec réducteurs planétaires en carter étanche sous bain d'huile. Freins d'arrêt à ressorts à desserrage hydraulique et freinage anti-usure hydraulique.

PARTIE SUPÉRIEURE

Contrepoids	295 t en combinaison avec 60 t de lest central.
Charpente	Structure mécano-soudée résistante à la déformation, réalisée en acier de construction à grains fins à haute résistance. Structure à longerons servant à recevoir trois treuils et le mécanisme de relevage. La partie supérieure est divisible en deux parties pour des raisons de transport.
Module de motorisation et de commande	Deux unités d'entraînement indépendantes l'une de l'autre, y compris la boîte de transfert à pompes et les pompes, sont disposées dans un module séparé attaché latéralement à la partie supérieure. Type de motorisation : moteur diesel Daimler type OM 502 LA. Puissance selon DIN 70020 : 380 kW (516 CV) à 2000 1/min, couple 2400 Nm à 1080 1/min. Le moteur satisfait aux règlements EUROMOT 3a, EPA T3 et Carb. Boîte de transfert à cinq pompes à pistons axiaux à débit variable et pompes à engrenage auxiliaires. La cabine, tout le système électrique et les équipements de génération de courant sont logés de série dans le module de motorisation et de commande. Réservoir de carburant : 2000 l.
Treuils	La partie supérieure est équipée de série de trois treuils – le treuil 1, le treuil 2 et le mécanisme de relevage. L'entraînement des treuils s'effectue avec réducteurs planétaires en carter étanche sous bain d'huile. Tous les treuils sont équipés de freins à disques multiples à ressorts à desserrage hydraulique et d'un freinage anti-usure hydraulique pour la descente. Les extrémités des câbles de tous les treuils sont munies des attaches à jonction rapide. Les treuils à verrouillage hydraulique H1 et H2 (H3 en option) sont démontables pour réduire les poids de transport
Commande	Demag IC-1 : Pilotage électronique de soupapes proportionnels intégré dans un automate programmable avec diagnostic de dysfonctionnement. Deux écrans couleur, commande du C.E.C. par écran tactile. Les vitesses de travail sont réglées sans paliers par la position du levier. Régulation automatique pour une exploitation optimale de la puissance du moteur. Limitation de portée et force de pression sur base en série.
Cabine	La cabine spacieuse et confortable est placée à la partie avant du module de motorisation et de commande. Large pare-brise et toit en vitrage blindé, climatisation commandée par ordinateur de série et chauffage à air chaud indépendant du moteur. Console frontale avec éléments de commande et de contrôle pour les fonctions de la grue ainsi que deux affichages graphiques. Cette console est inclinable en arrière avec le siège conducteur, assurant au grutier une visibilité optimale. Systèmes de caméra pour surveiller les treuils et lest SL, compteur d'heures de service, affichage du moment de charge, 2 projecteurs de travail, armoires de rangement et réfrigérateur livrés de série.
Installation électrique	Système 24 V (2 batteries 12 V / 180 Ah). Génératrice à courant alternatif triphasé 24 V, 80 A. Génératrice triphasée supplémentaire à 400 V 50 Hz 20 kVA pour la climatisation, le chauffage, l'éclairage et de multiples applications sur le chantier. Groupe électrogène de secours 400 V 50 Hz 16 kVA.
Connexion rapide	Connexion rapide hydraulique entre partie supérieure et châssis en série.

EQUIPEMENTS OPTIONNELS

Chariot contrepoids	Le chariot contrepoids avec un poids total maxi de 640 t peut être librement ajusté sur une distance comprise entre 19 m et 25 m ou entre 24 m et 30 m du centre de rotation et peut être opéré dans les modes de déplacement du genre circulaire, marche derrière $\pm 30^\circ$ et marche en parallèle. Poids mort 130 t, démontable en trois parties pour un transport facile.
----------------------------	---

Contrepoids Superlift

Équipements optionnels supplémentaires sur demande!



CC9800
 CRAWLER CRANE

DESCRIPTIF TECHNIQUE
COMBINAISONS DE FLÈCHE

Général	Construction tubulaire treillie en acier de haute résistance à grains fins. Passerelles sur flèche principale, volée variable et mât superlift. Verrouillage hydraulique.
SSL	Flèche principale : pied 10 m, tronçons 6 m et 12 m, tête de flèche 2 m avec 2 jeux de poulies. Équipement Superlift. Longueurs de flèche principale : 54-108 m
SSL / LSL (SGL 108 m)	Flèche principale : pied 10 m, tronçons 6 m et 12 m (type 3629), tronçon conique, allongée de tronçons 6 m et 12 m (type 3227), tête pour charges lourdes 2 m avec 1 jeu de poulie de flèche principale SSL. Équipement Superlift. Longueurs de flèche principale : 114-156 m
SWSL	Flèche principale : idem SSL. Inclinaison 88° à 55°. Fléchette à volée variable : pied 10 m, tronçon 12 m (type 3629), tronçon conique, tronçons 6 m et 12 m, tête pour charges lourdes 2 m avec 1 jeu de poulie de flèche principale SSL. Équipement Superlift. Longueurs de flèche principale : 60-108 m Longueurs de volée variable : 36-120 m
SFSL	idem SWSL. Inclinaison de fléchette 15°.
SFVL	Flèche principale : idem SSL. Fléchette fixe : pied 10 m, tronçon conique, tête pour charges lourdes 2 m avec 2 jeux de poulies de flèche principale SSL. Équipement Superlift. Longueurs de flèche principale : 60-108 m Longueur de volée variable : 18 m Inclinaison : 15°
+LF	En plus SSL/LSL. Fléchette fixe : pied 9 m, tronçon de tête 9 m. Longueurs de flèche principale : 114-144 m Longueur de volée variable : 18 m Inclinaison : 20°
Boulonnement de flèche	Boulonnement hydraulique des intercalaires de flèche en série.
Tambour de mouflage	Monté sur la partie supérieure en série.
Sécurités	Contrôleur d'état de charge électronique, contacteur de fin de course haut, limiteurs de mouvements de la flèche, retenues hydrauliques anti-basculement de la flèche, anémomètre.

COMBINAISONS SUPERLIFT

Tele-SL	Mât 50 m (type 2621), panier du contrepoids 800 t ou chariot contrepoids en option avec max. 640 t. Rayon du Superlift variable de 19 m à 25 m pour un rayon de mât 22 m et de 24 m à 30 m pour un rayon de mât 26,4 m.
----------------	--

EQUIPEMENTS OPTIONNELS

Potence de 60 t	Environ 3 m, montage en tête de flèche et tête pour charges lourdes.
Treuil H3	Monté sur la partie supérieure.

6





NOTES TO LIFTING CAPACITY · ANMERKUNGEN ZU DEN TRAGFÄHIGKEITEN · CONDITIONS D'UTILISATION

Ratings are in compliance with ISO 4305.

Weight of hook blocks and slings is part of the load, and is to be deducted from the capacity ratings.

Consult operation manual for further details.

Note: Data published herein is intended as a guide only and shall not be construed to warrant applicability for lifting purposes.

Crane operation is subject to the computer charts and operation manual both supplied with the crane.

In some instances the superlift counterweight does not lift off the ground with the indicated load.

Tragfähigkeiten entsprechen ISO 4305.

Das Gewicht der Unterflaschen, sowie die Lastaufnahmemittel, sind Bestandteile der Last und sind von den Tragfähigkeitsangaben abzuziehen.

Weitere Angaben in der Bedienungsanleitung des Kranes.

Anmerkung: Die Daten dieser Broschüre dienen nur zur allgemeinen Information; für ihre Richtigkeit übernehmen wir keine Haftung.

Der Betrieb des Kranes ist nur mit den Original-Tragfähigkeitstabellen und mit der Bedienungsanleitung zulässig, die mit dem Kran mitgeliefert werden.

In einigen Fällen hebt das Superliftgegengewicht bei den angegebenen Traglasten nicht ab.

Le tableau de charges est conforme à la norme ISO 4305.

Les poids du crochet-moufle et de tous les accessoires d'élingage font partie de la charge et sont à déduire des charges indiquées.

Pour plus de détails consulter la notice d'utilisation de la grue.

Nota: Les renseignements ci-inclus sont donnés à titre indicatif et ne représentent aucune garantie d'utilisation pour les opérations de levage.

La mise en service de la grue n'est autorisée qu'à condition que les tableaux de charges ainsi que le manuel de service, tels que fournis avec la grue, soient observés.











Le contrepoids du superlift ne décolle pas dans certaines configurations des tableaux de charge.





CC9800
CRAWLER CRANE

KEY · ZEICHENERKLÄRUNG · LÉGENDE

-  Track · Spur · Voie
-  Counterweight + central ballast (ZB) · Gegengewicht + Zentralballast (ZB) · Contrepoids + lest central (ZB)
-  Superlift counterweight · Superlift-Gegengewicht · Contrepoids Superlift
-  Superlift radius · Superlift-Radius · rayon Superlift
-  Load radius · Lastradius · Portée
-  Main boom · Hauptausleger · Flèche principale
-  Fly jib · Hilfsausleger · Fléchette
-  Main boom angle · Hauptauslegerwinkel · Jarret de flèche principale
-  Fly jib angle · Hilfsauslegerwinkel · Jarret de fléchette
-  „D”
- S: heavy · schwer · lourd
- L: light · leicht · léger
- H: Main boom · Hauptausleger · Flèche principale
- W: Luffing fly jib · Wippbarer Hilfsausleger · Fléchette à volée variable
- F: Fixed fly jib · Starrer Hilfsausleger · Fléchette fixe
- SL: Superlift
- SGL: Heavy base length · Schwere Grundlänge · Longueur de base lourde

6



CC9800
 CRAWLER CRANE

Effective Date: may 2009.

Product specifications and prices are subject to change without notice or obligation. The photographs and/or drawings in this document are for illustrative purposes only. Refer to the appropriate Operator's Manual for instructions on the proper use of this equipment. Failure to follow the appropriate Operator's Manual when using our equipment or to otherwise act irresponsibly may result in serious injury or death. The only warranty applicable to our equipment is the standard written warranty applicable to the particular product and sale and Terex makes no other warranty, express or implied. Products and services listed may be trademarks, service marks or trade-names of Terex Corporation and/or its subsidiaries in the USA and other countries and all rights are reserved. „TEREX“ is a registered trademark of Terex Corporation in the USA and many other countries.

Copyright © 2009 Terex Corporation.

Gültig ab: Mai 2009.

Produktbeschreibungen und Preise können jederzeit und ohne Verpflichtung zur Ankündigung geändert werden. Die in diesem Dokument enthaltenen Fotos und/oder Zeichnungen dienen rein anschaulichen Zwecken. Anweisungen zur ordnungsgemäßen Verwendung dieser Ausrüstung entnehmen Sie bitte dem zugehörigen Betriebshandbuch. Nichtbefolgung des Betriebshandbuchs bei der Verwendung unserer Produkte oder anderweitig fahrlässiges Verhalten kann zu schwerwiegenden Verletzungen oder Tod führen. Für dieses Produkt wird ausschließlich die entsprechende, schriftlich niedergelegte Standardgarantie gewährt. Terex leistet keinerlei darüber hinaus gehende Garantie, weder ausdrücklich noch stillschweigend. Die Bezeichnungen der aufgeführten Produkte und Leistungen sind gegebenenfalls Marken, Servicemarken oder Handelsnamen der Terex Corporation und/oder ihrer Tochtergesellschaften in den USA und anderen Ländern. Alle Rechte vorbehalten. „TEREX“ ist eine eingetragene Marke der Terex Corporation in den USA und vielen anderen Ländern.

Copyright © 2009 Terex Corporation.

Date d'effet : le mai 2009.

Les spécifications et prix des produits sont sujets à modification sans avis ou obligation. Les photographies et/ou dessins contenus dans ce documents sont uniquement pour illustration. Veuillez vous référer à la notice d'utilisation appropriée pour les instructions quant à l'utilisation correcte de cet équipement. Tout manquement au suivi de la notice d'utilisation appropriée lors de l'utilisation de notre équipement ou tout acte autrement irresponsable peut résulter en blessure corporelle sérieuse ou mortelle. La seule garantie applicable à notre équipement est la garantie standard écrite applicable à un produit et à une vente spécifique. Terex n'offre aucune autre garantie, expresse ou explicite. Les produits et services proposés peuvent être des marques de fabrique, des marques de service ou des appellations commerciales de Terex Corporation et/ou ses filiales aux Etats Unis et dans les autres pays, et tous les droits sont réservés. «TEREX» est une marque déposée de Terex Corporation aux Etats Unis et dans de nombreux autres pays.

Copyright © 2009 Terex Corporation.



Registered office / Lieferanschrift / Siège social:

Terex-Demag GmbH Phone: + 49 6332 83-0
 Dinglerstraße 24 Fax: + 49 6332 16715
 D-66482 Zweibrücken www.terex-demag.com

Bigge Crane and Rigging Co.

10700 Bigge Avenue
 San Leandro, CA 94577
 Phone: (888) 337-BIGGE or (510) 638-8100
 Fax: (510) 639-4053
 Email: info@bigge.com
 Web site: www.bigge.com

Order Nr. CC 9800 A1 – 201 274 12

