



AC 140 | All Terrain Crane 170 t Lifting Capacity



AC 140

ALL TERRAIN CRANE

 **TEREX | DEMAG**

AC 140

HIGHLIGHTS

- ▶ 17,650 lb counterweight carried on the crane giving just 26,450 lb axle load
- ▶ 196.9 ft main boom and optional 29.9 ft to 108.3 ft boom extension
- ▶ State-of-the-art engine and transmission ensure high travel comfort
- ▶ Speed-dependent rear axle steering for increased maneuverability and driving stability
- ▶ Innovative Demag IC-1 crane control system with touchscreen

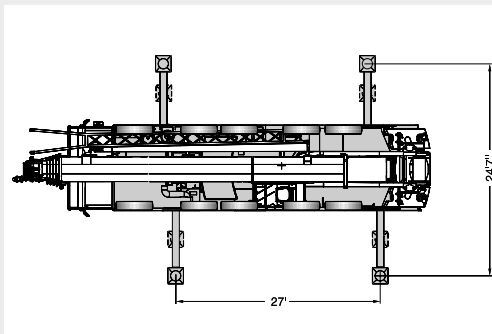
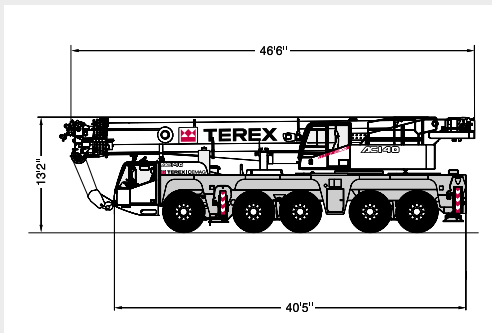
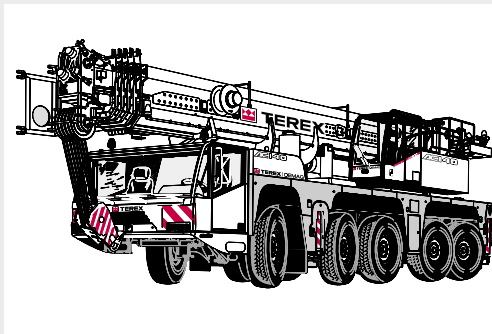

ALL TERRAIN CRANE **AC 140**

CONTENTS

	Page:	
Technical data		
Dimensions	4	1
Axle weight with dolly	6	
Specifications	7	
Main boom		
Working ranges	8	2
Lifting capacities	9	
Main boom extension		
Working ranges	12	3
Lifting capacities	13	
Working ranges	16	
Technical description		
Carrier · Superstructure · Optional equipment	17	4





DIMENSIONS

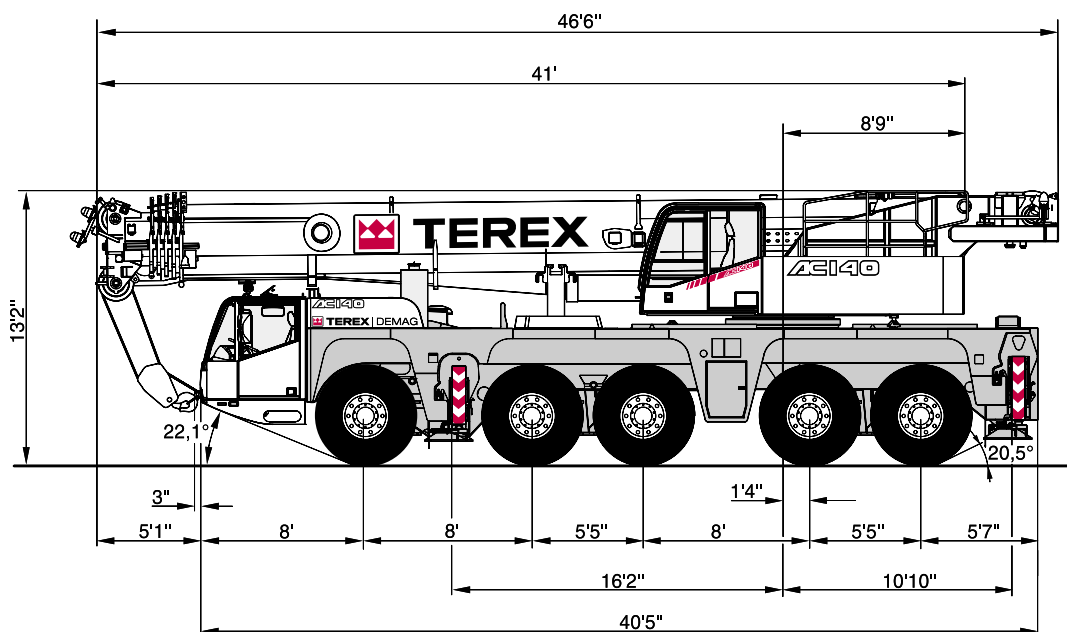

**ALL TERRAIN CRANE
AC 140**

DIMENSIONS

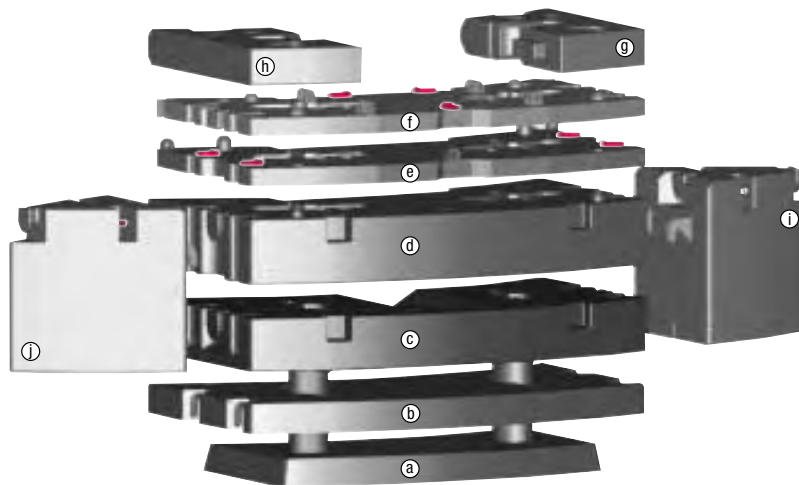

	a) 8,200 lb	b) 4,400 lb	c) 17,400 lb	d) 21,100 lb	e) 5,700 lb	f) 5,700 lb	g) 2,900 lb	h) 2,900 lb	i) 8,800 lb	j) 8,800 lb
0 lb										
13,900 lb	X						X	X		
18,300 lb	X	X					X	X		
23,800 lb	X	X				X	X	X		
29,800 lb	X	X			X	X	X	X		
29,800 lb	X	X	X							
41,500 lb	X	X	X			X	X	X		
47,100 lb	X	X	X		X	X	X	X		
51,200 lb	X	X	X	X						
56,900 lb	X	X	X	X			X	X		
62,600 lb	X	X	X	X	X	X				
68,300 lb	X	X	X	X	X	X	X	X		
68,300 lb	X	X	X	X					X	X
86,000 lb	X	X	X	X	X	X	X	X	X	X

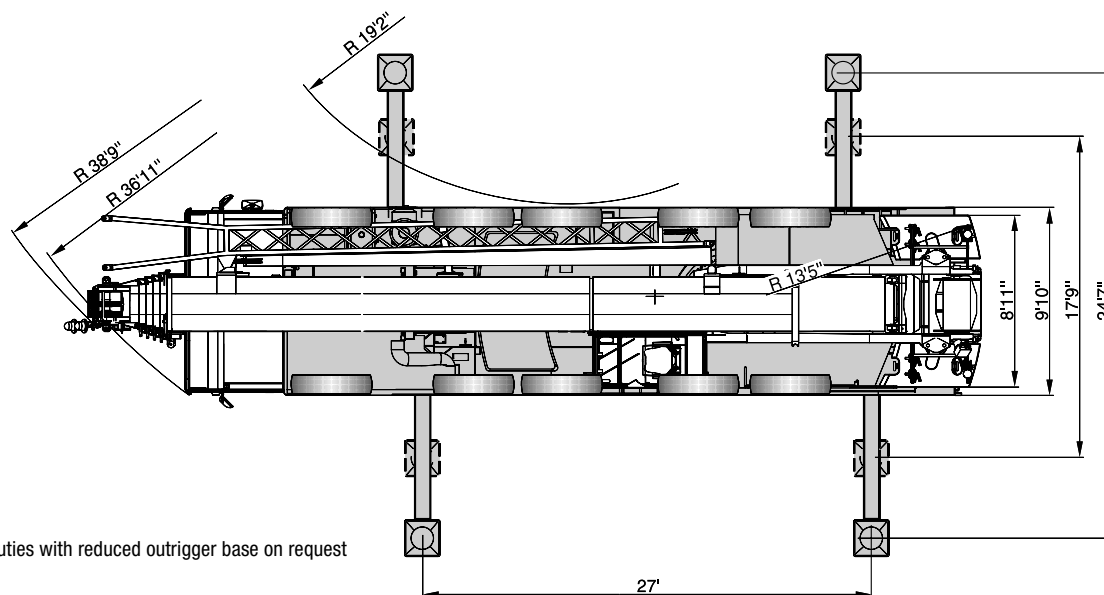
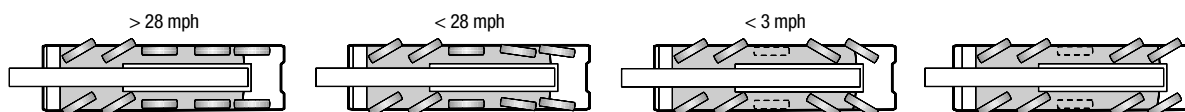

* Duties with reduced outrigger base on request



TEREX | DEMAG

AXLE WEIGHT WITH DOLLY AC 140

CRANE CONFIGURATION

Drive	10 x 8 x 8
Tires	20.5 R 25
Outrigger front	
Outrigger rear	
Hook block 1-sheave	
2-axle boom dolly	5.700 lb

AXLES

Axle	1	2	3	4	5	6	7	Total weight
Weight	19,200 lb	19,200 lb	17,200 lb	17,200 lb	17,000 lb	17,450 lb	17,450 lb	124,700 lb

More configurations on request!

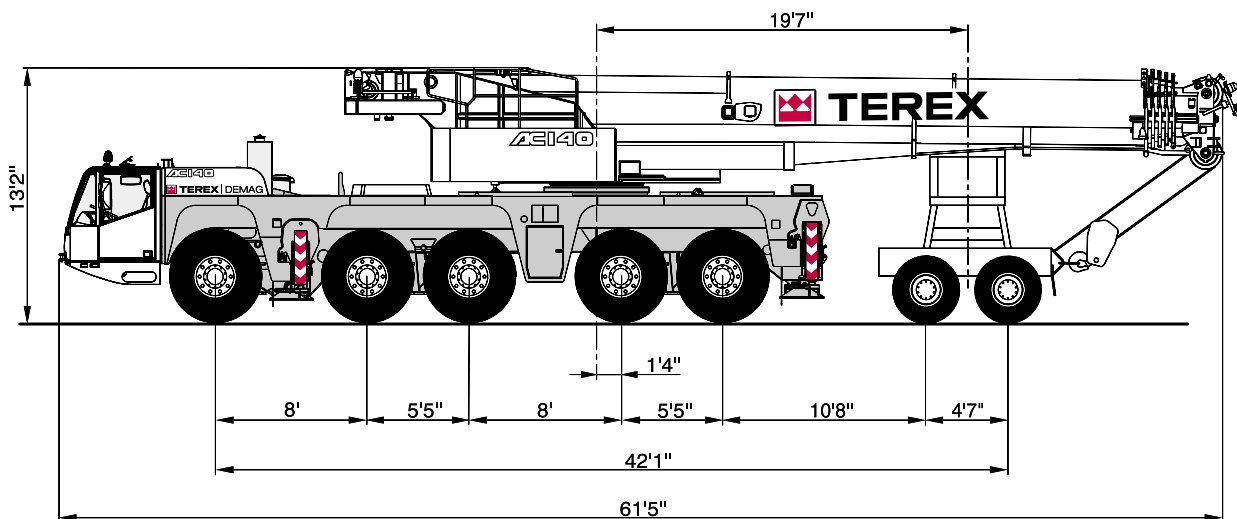

**ALL TERRAIN CRANE
AC 140**

SPECIFICATIONS

AXLE LOADS

UFL 1-sheave, main boom extension 55.8 ft, 13,700 lb counterweight

UFL 1-sheave, 17,600 lb counterweight

Axles 5 x 26,500 lb

Total weight 132,500 lb

Additional versions and axle loads for offroad travelling on request.

WORKING SPEEDS (INFINITELY VARIABLE)

Mechanisms	Normal speed	High speed ²⁾	Max. permissible line pull ¹⁾	Rope diameter / Rope length
Hoist I	148 ft/min	476 ft/min	18,200 lb	0.83" / 1000 ft
Hoist II	148 ft/min	476 ft/min	18,200 lb	0.83" / 1000 ft
Slewing				max. 1.7 ¹ /min
Boom elevation				-1.5° – +82°

CARRIER PERFORMANCE

Travel speed 0 .. 53 mph

Gradeability 70 %

HOOK BLOCK / SINGLE LINE HOOK

Type	Possible load ¹⁾	Number of sheaves	Weight	„D“	Number of lines	Heavy-lift attachment
200	296,500 lb	9	3,860 lb	9.8 ft	18	4 add'l. sheaves + hoist 2
100	219,350 lb	7	2,200 lb	9.8 ft	13	2 add'l. sheaves
80	171,300 lb	5	2,050 lb	9.8 ft	10	
63	121,700 lb	3	1,550 lb	9.8 ft	7	
32	53,150 lb	1	1,200 lb	8.6 ft	3	
8	17,650 lb	Single line hook	550 lb	6.6 ft	1	

Remarks

1) varies depending on national regulations

2) at max. rope's layer





WORKING RANGES MAIN BOOM

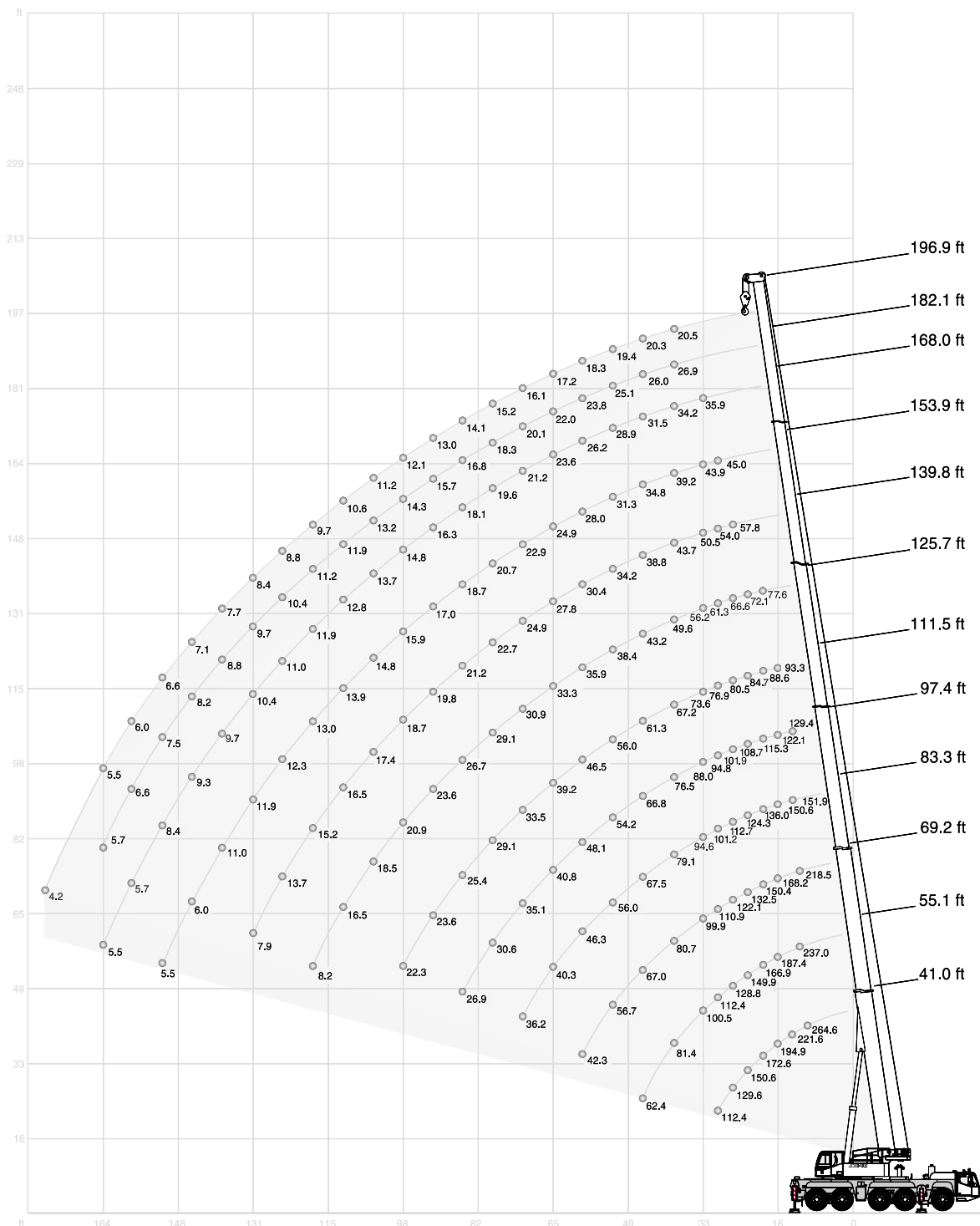

**ALL TERRAIN CRANE
AC 140**

LIFTING CAPACITIES MAIN BOOM

86,000 lb

360°

85 %

Radius	Main boom												Radius	
	ft	41.0	55.1	69.2	83.3	97.4	111.5	125.7	139.8	153.9	168.0	182.1		196.9
		340.0*	-	-	-	-	-	-	-	-	-	-	-	
10		264.6	237.0	218.5	151.9	-	-	-	-	-	-	-	-	10
12		238.1	223.8	203.9	145.5	-	-	-	-	-	-	-	-	12
13		221.6	213.4	189.6	166.2	129.4	-	-	-	-	-	-	-	13
15		207.7	199.5	178.8	158.3	125.7	-	-	-	-	-	-	-	15
16		194.9	187.4	168.2	150.6	122.1	93.3	-	-	-	-	-	-	16
20		172.6	166.9	150.4	136.0	115.3	88.6	77.6	-	-	-	-	-	20
23		150.6	149.9	132.5	124.3	108.7	84.7	72.1	-	-	-	-	-	23
26		129.6	128.8	122.1	112.7	101.9	80.5	66.6	57.8	-	-	-	-	26
30		112.4	112.4	110.9	101.2	94.8	76.9	61.3	54.0	45.0	-	-	-	30
33		-	100.5	99.9	94.6	88.0	73.6	56.2	50.5	43.9	35.9	-	-	33
39		-	81.4	80.7	79.1	76.5	67.2	49.6	43.7	39.2	34.2	26.9	20.5	39
46		-	62.4	67.0	67.5	66.8	61.3	43.2	38.8	34.8	31.5	26.0	20.3	46
53		-	-	56.7	56.0	54.2	56.0	38.4	34.2	31.3	28.9	25.1	19.4	53
59		-	-	42.3	46.3	48.1	46.5	35.9	30.4	28.0	26.2	23.8	18.3	59
66		-	-	-	40.3	40.8	39.2	33.3	27.8	24.9	23.6	22.0	17.2	66
72		-	-	-	36.2	35.1	33.5	30.9	24.9	22.9	21.2	20.1	16.1	72
79		-	-	-	-	30.6	29.1	29.1	22.7	20.7	19.6	18.3	15.2	79
85		-	-	-	-	26.9	25.4	26.7	21.2	18.7	18.1	16.8	14.1	85
92		-	-	-	-	-	23.6	23.6	19.8	17.0	16.3	15.7	13.0	92
98		-	-	-	-	-	22.3	20.9	18.7	15.9	14.8	14.3	12.1	98
105		-	-	-	-	-	-	18.5	17.4	14.8	13.7	13.2	11.2	105
112		-	-	-	-	-	-	16.5	16.5	13.9	12.8	11.9	10.6	112
118		-	-	-	-	-	-	8.2	15.2	13.0	11.9	11.2	9.7	118
125		-	-	-	-	-	-	-	13.7	12.3	11.0	10.4	8.8	125
131		-	-	-	-	-	-	-	7.9	11.9	10.4	9.7	8.4	131
138		-	-	-	-	-	-	-	-	11.0	9.7	8.8	7.7	138
144		-	-	-	-	-	-	-	-	6.0	9.3	8.2	7.1	144
151		-	-	-	-	-	-	-	-	5.5	8.4	7.5	6.6	151
158		-	-	-	-	-	-	-	-	-	5.7	6.6	6.0	158
164		-	-	-	-	-	-	-	-	-	5.5	5.7	5.5	164
177		-	-	-	-	-	-	-	-	-	-	-	4.2	177
190		-	-	-	-	-	-	-	-	-	-	-	-	190

Remarks

* with special attachment, on request





LIFTING CAPACITIES MAIN BOOM

		47,200 lb											360°		85 %	
		Main boom														
Radius	ft	41.0	55.1	69.2	83.3	97.4	111.5	125.7	139.8	153.9	168.0	182.1	196.9	Radius	ft	
	ft	1,000 lb												ft		
10	264.6	237.0	218.5	151.9	-	-	-	-	-	-	-	-	-	10	10	
12	238.1	223.8	203.9	145.5	-	-	-	-	-	-	-	-	-	12	12	
13	221.6	213.4	189.6	166.2	129.4	-	-	-	-	-	-	-	-	13	13	
15	207.7	199.5	178.8	158.3	125.7	-	-	-	-	-	-	-	-	15	15	
16	194.7	187.4	168.2	150.6	122.1	93.3	-	-	-	-	-	-	-	16	16	
20	160.5	159.8	150.4	136.0	115.3	88.6	77.6	-	-	-	-	-	-	20	20	
23	134.3	133.6	131.8	124.3	108.7	84.7	72.1	-	-	-	-	-	-	23	23	
26	115.1	115.7	115.1	112.7	101.9	80.5	66.6	57.8	-	-	-	-	-	26	26	
30	99.6	100.8	100.1	95.7	93.0	76.9	61.3	54.0	45.0	-	-	-	-	30	30	
33	-	83.3	82.5	84.9	80.2	73.6	56.2	50.5	43.9	35.9	-	-	-	33	33	
39	-	61.7	62.2	61.3	63.3	61.3	49.6	43.7	39.2	34.2	26.9	20.5	-	39	39	
46	-	42.1	48.9	49.8	48.7	47.0	43.2	38.8	34.8	31.5	26.0	20.3	-	46	46	
53	-	-	40.1	39.9	38.8	37.3	38.4	34.2	31.3	28.9	25.1	19.4	-	53	53	
59	-	-	26.0	32.8	31.7	33.3	31.7	29.3	28.0	26.2	23.8	18.3	-	59	59	
66	-	-	-	27.6	28.0	27.8	26.5	26.7	24.0	23.6	22.0	17.2	-	66	66	
72	-	-	-	23.6	24.7	23.6	22.7	22.9	21.4	20.5	20.1	16.1	-	72	72	
79	-	-	-	-	21.4	20.3	20.7	19.6	19.4	18.5	18.3	15.2	-	79	79	
85	-	-	-	-	18.7	17.6	18.1	16.8	16.5	16.3	15.4	14.1	-	85	85	
92	-	-	-	-	-	16.3	15.7	15.7	14.8	13.9	13.0	12.8	-	92	92	
98	-	-	-	-	-	14.8	13.7	13.4	12.8	11.9	10.8	10.8	-	98	98	
105	-	-	-	-	-	-	12.1	11.7	11.0	10.1	9.0	9.0	-	105	105	
112	-	-	-	-	-	-	11.2	10.4	9.5	8.6	7.7	7.5	-	112	112	
118	-	-	-	-	-	-	8.2	9.0	8.2	7.3	6.4	6.2	-	118	118	
125	-	-	-	-	-	-	-	7.9	7.3	6.2	5.1	5.1	-	125	125	
131	-	-	-	-	-	-	-	7.1	6.2	5.1	4.2	4.0	-	131	131	
138	-	-	-	-	-	-	-	-	5.3	4.2	3.3	3.1	-	138	138	
144	-	-	-	-	-	-	-	-	4.4	3.3	2.4	2.2	-	144	144	
151	-	-	-	-	-	-	-	-	3.7	2.6	1.5	1.5	-	151	151	
158	-	-	-	-	-	-	-	-	-	2.0	-	-	-	158	158	

		13,900 lb											360°		85 %	
		Main boom														
Radius	ft	41.0	55.1	69.2	83.3	97.4	111.5	125.7	139.8	153.9	168.0	182.1	196.9	Radius	ft	
	ft	1,000 lb												ft		
10	264.6	237.0	218.5	151.9	-	-	-	-	-	-	-	-	-	10	10	
12	238.1	223.8	203.9	145.5	-	-	-	-	-	-	-	-	-	12	12	
13	221.6	213.4	189.6	166.2	129.4	-	-	-	-	-	-	-	-	13	13	
15	201.5	199.5	178.8	158.3	125.7	-	-	-	-	-	-	-	-	15	15	
16	178.1	177.5	168.2	150.6	122.1	93.3	-	-	-	-	-	-	-	16	16	
20	144.2	142.0	130.3	118.8	108.7	88.6	77.6	-	-	-	-	-	-	20	20	
23	110.9	110.7	102.5	96.1	87.7	83.3	72.1	-	-	-	-	-	-	23	23	
26	81.6	85.8	84.9	79.6	76.1	68.3	63.3	57.8	-	-	-	-	-	26	26	
30	63.5	69.0	68.6	69.2	63.5	57.1	53.6	50.5	45.0	-	-	-	-	30	30	
33	-	56.0	57.8	57.5	54.0	50.5	48.7	43.9	40.8	35.9	-	-	-	33	33	
39	-	39.7	41.0	41.0	41.9	41.0	37.5	36.4	34.0	30.4	26.9	20.5	-	39	39	
46	-	23.1	31.1	32.8	32.4	31.3	32.0	29.8	28.7	26.2	24.3	20.3	-	46	46	
53	-	-	25.4	26.0	25.6	26.0	25.1	24.9	23.1	21.2	19.2	18.5	-	53	53	
59	-	-	17.2	20.9	21.4	21.2	20.9	20.1	19.0	17.0	15.4	14.6	-	59	59	
66	-	-	-	17.6	17.6	17.6	17.2	16.8	15.4	13.7	12.1	11.2	-	66	66	
72	-	-	-	14.8	14.8	14.8	14.3	13.7	12.6	11.0	9.5	8.6	-	72	72	
79	-	-	-	-	12.6	12.1	11.7	11.0	10.1	8.8	7.3	6.6	-	79	79	
85	-	-	-	-	10.6	10.1	9.7	9.0	8.2	6.8	5.5	4.9	-	85	85	
92	-	-	-	-	-	8.6	8.2	7.5	6.6	5.3	4.0	3.5	-	92	92	
98	-	-	-	-	-	7.1	6.6	6.0	5.1	4.0	2.9	2.2	-	98	98	
105	-	-	-	-	-	-	5.5	4.6	4.0	2.9	1.8	-	-	105	105	
112	-	-	-	-	-	-	4.4	3.7	2.9	1.8	-	-	-	112	112	
118	-	-	-	-	-	-	3.5	2.9	2.0	-	-	-	-	118	118	
125	-	-	-	-	-	-	-	2.0	-	-	-	-	-	125	125	
131	-	-	-	-	-	-	-	-	-	-	-	-	-	131	131	



**ALL TERRAIN CRANE
AC 140**

LIFTING CAPACITIES MAIN BOOM

☰ 0 lb

⚙️ 360°

85 %

Radius	Main boom													Radius
	ft	41.0	55.1	69.2	83.3	97.4	111.5	125.7	139.8	153.9	168.0	182.1	196.9	
ft	1,000 lb													ft
10	264.6	237.0	218.5	151.9	-	-	-	-	-	-	-	-	-	10
12	238.1	223.8	203.9	145.5	-	-	-	-	-	-	-	-	-	12
13	219.6	213.4	188.5	161.4	129.4	-	-	-	-	-	-	-	-	13
15	192.9	189.6	161.6	133.8	117.1	-	-	-	-	-	-	-	-	15
16	170.4	153.4	132.1	118.4	100.3	92.6	-	-	-	-	-	-	-	16
20	117.1	110.2	100.5	92.4	82.9	73.6	64.6	-	-	-	-	-	-	20
23	77.6	84.0	79.4	74.3	66.1	61.1	55.6	-	-	-	-	-	-	23
26	56.4	61.9	63.7	60.6	54.7	52.7	48.3	44.5	-	-	-	-	-	26
30	43.4	48.3	49.8	49.6	49.6	44.8	42.8	40.1	36.8	-	-	-	-	30
33	-	38.8	40.3	42.3	41.9	39.9	37.0	34.8	32.0	28.7	-	-	-	33
39	-	27.1	29.3	30.0	30.6	30.2	29.5	26.9	24.5	21.8	19.6	18.3	-	39
46	-	13.9	22.0	22.9	22.9	22.9	22.7	21.2	19.2	16.8	15.0	13.9	-	46
53	-	-	17.4	17.9	18.3	17.9	17.6	16.8	15.2	13.0	11.2	10.6	-	53
59	-	-	13.7	14.1	14.6	14.3	13.9	13.4	12.1	10.1	8.6	7.9	-	59
66	-	-	-	11.5	11.9	11.5	11.2	10.6	9.5	7.7	6.2	5.7	-	66
72	-	-	-	9.3	9.7	9.3	9.0	8.6	7.5	5.7	4.4	3.7	-	72
79	-	-	-	-	7.9	7.7	7.3	6.8	5.7	4.2	2.9	2.2	-	79
85	-	-	-	-	6.6	6.2	6.0	5.5	4.4	2.9	-	-	-	85
92	-	-	-	-	-	5.1	4.6	4.0	3.1	1.5	-	-	-	92
98	-	-	-	-	-	4.0	3.5	2.9	2.0	-	-	-	-	98
105	-	-	-	-	-	-	2.6	1.8	-	-	-	-	-	105
112	-	-	-	-	-	-	-	1.8	-	-	-	-	-	112
118	-	-	-	-	-	-	-	-	-	-	-	-	-	118





WORKING RANGES MAIN BOOM EXTENSION

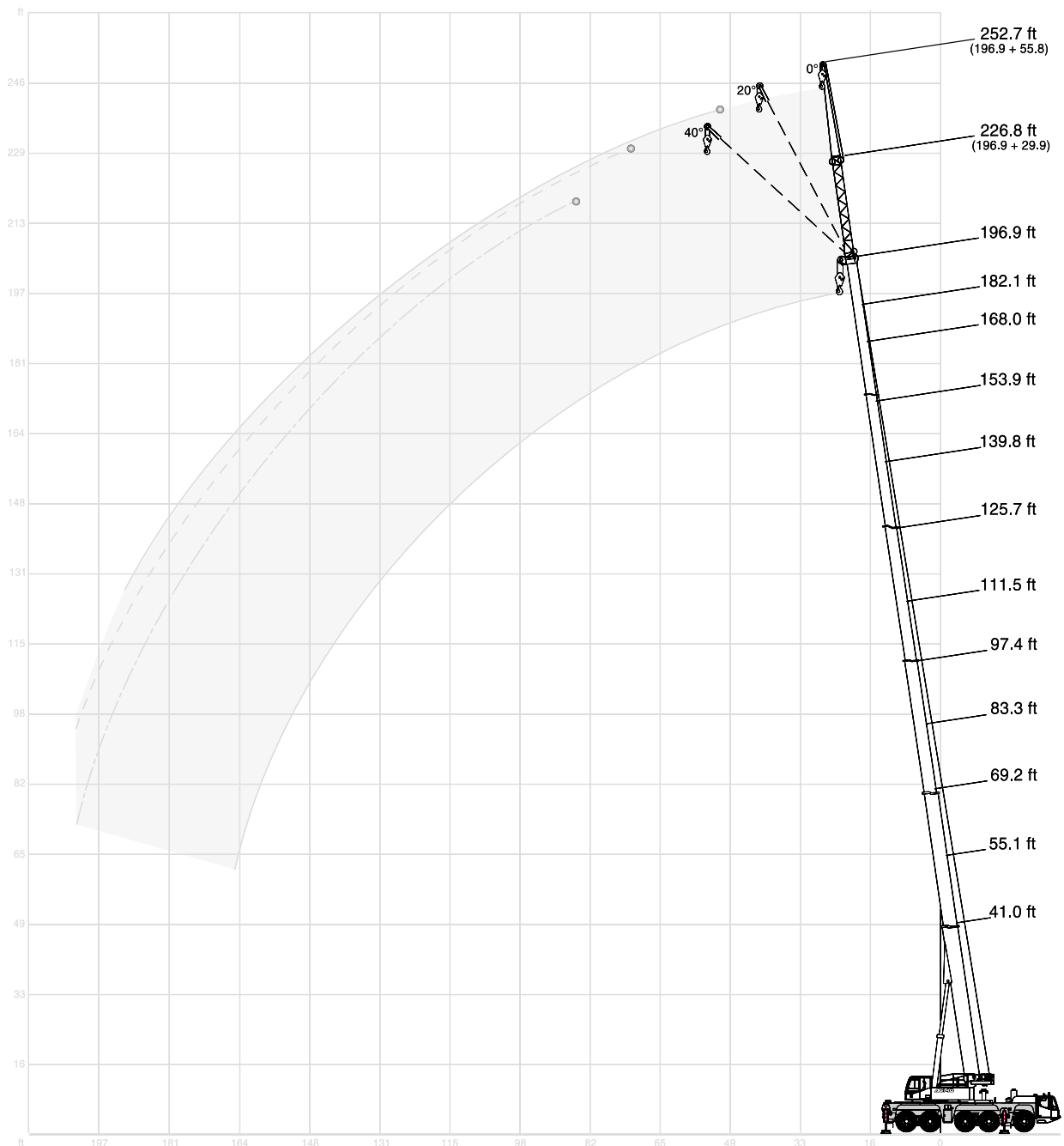

**ALL TERRAIN CRANE
AC 140**

LIFTING CAPACITIES MAIN BOOM EXTENSION

86,000 lb

360°

85 %

41.0 ft Main boom		Extension					
Radius	29.9 ft			55.8 ft			
	0°	20°	40°	0°	20°	40°	
ft	1,000 lb						
10	35.7	-	-	23.4	-	-	
12	35.7	-	-	22.5	-	-	
13	35.7	-	-	21.6	-	-	
15	34.8	-	-	20.7	-	-	
16	34.0	25.4	-	20.1	-	-	
20	31.7	23.8	-	18.5	-	-	
23	29.5	22.5	-	17.2	-	-	
26	27.8	21.4	17.2	16.1	-	-	
30	25.8	20.5	16.5	15.0	12.1	-	
33	24.0	19.6	16.1	14.1	11.5	-	
39	21.4	18.1	15.0	12.8	10.6	-	
46	19.2	16.8	14.1	11.5	9.7	8.4	
53	17.6	15.9	13.9	10.4	8.8	7.7	
59	16.3	15.9	-	9.5	8.4	7.5	
66	-	-	-	8.6	7.7	7.1	
72	-	-	-	7.9	7.3	6.8	
79	-	-	-	7.5	7.1	6.8	
85	-	-	-	-	6.8	-	
92	-	-	-	-	-	-	
98	-	-	-	-	-	-	
105	-	-	-	-	-	-	
112	-	-	-	-	-	-	
118	-	-	-	-	-	-	

139.8 ft Main boom		Extension					
Radius	29.9 ft			55.8 ft			
	0°	20°	40°	0°	20°	40°	
ft	1,000 lb						
33	29.5	-	-	15.7	-	-	
39	27.8	-	-	14.8	-	-	
46	26.2	19.8	-	13.9	-	-	
53	24.7	19.0	15.4	13.0	10.1	-	
59	23.4	18.3	15.0	12.3	9.5	-	
66	22.3	17.6	14.6	11.7	9.3	-	
72	20.9	17.0	14.3	11.2	8.8	7.3	
79	19.4	16.3	14.1	10.6	8.4	7.1	
85	17.9	15.7	13.9	10.1	8.2	6.8	
92	16.3	15.0	13.7	9.7	7.7	6.8	
98	14.8	14.3	13.4	9.3	7.5	6.6	
105	13.7	13.4	13.2	8.8	7.3	6.4	
112	12.6	12.8	12.8	8.4	7.1	6.4	
118	11.7	11.9	11.9	7.9	6.8	6.4	
125	10.8	11.0	11.0	7.7	6.6	6.2	
131	9.9	10.1	10.1	7.5	6.6	6.2	
138	9.5	9.3	9.5	7.3	6.4	6.2	
144	9.0	9.0	9.3	6.8	6.4	6.2	
151	8.6	8.6	4.6	6.6	6.2	6.2	
158	4.4	4.4	-	6.4	6.2	6.2	
164	-	-	-	6.2	6.0	6.2	
177	-	-	-	6.0	5.7	3.1	
190	-	-	-	-	-	-	

168.0 ft Main boom		Extension					
Radius	29.9 ft			55.8 ft			
	0°	20°	40°	0°	20°	40°	
ft	1,000 lb						
39	22.5	-	-	-	-	-	
46	21.8	-	-	12.3	-	-	
53	20.9	17.6	-	11.9	-	-	
59	20.3	17.0	14.3	11.2	-	-	
66	19.2	16.5	14.1	10.8	8.8	-	
72	17.9	15.9	13.9	10.4	8.4	-	
79	16.5	15.2	13.7	9.9	8.2	6.8	
85	15.2	14.6	13.4	9.7	7.7	6.8	
92	13.9	13.9	13.2	9.3	7.5	6.6	
98	13.0	13.0	13.0	8.8	7.3	6.4	
105	11.9	12.1	12.3	8.6	7.1	6.4	
112	11.0	11.2	11.5	8.2	6.8	6.2	
118	9.9	10.4	10.6	7.9	6.8	6.2	
125	9.0	9.5	9.7	7.7	6.6	6.0	
131	8.6	8.6	8.8	7.5	6.4	6.0	
138	7.9	7.9	8.2	7.1	6.4	6.0	
144	7.5	7.5	7.5	6.8	6.2	6.0	
151	6.8	7.1	7.1	6.4	6.0	6.0	
158	6.4	6.4	6.6	6.0	5.7	5.7	
164	6.0	6.2	6.2	5.5	5.5	5.5	
177	4.4	4.6	3.3	4.6	4.9	4.9	
190	2.6	2.6	-	3.7	4.2	4.2	
203	-	-	-	2.6	2.9	2.0	

196.9 ft Main boom		Extension					
Radius	29.9 ft			55.8 ft			
	0°	20°	40°	0°	20°	40°	
ft	1,000 lb						
46	13.2	-	-	-	-	-	
53	13.2	-	-	8.6	-	-	
59	13.0	12.6	-	8.6	-	-	
66	12.3	12.1	11.9	8.4	-	-	
72	11.9	11.7	11.5	8.2	7.7	-	
79	11.5	11.2	11.0	7.9	7.5	-	
85	10.8	10.8	10.6	7.7	7.3	6.4	
92	10.1	10.1	10.1	7.5	7.1	6.2	
98	9.7	9.7	9.7	7.3	6.8	6.2	
105	9.0	9.3	9.3	7.1	6.6	6.0	
112	8.4	8.6	8.8	6.8	6.4	6.0	
118	7.9	8.2	8.4	6.6	6.2	5.7	
125	7.3	7.5	7.7	6.2	6.0	5.7	
131	6.8	7.1	7.3	5.7	5.7	5.5	
138	6.2	6.4	6.6	5.3	5.5	5.5	
144	5.5	6.0	6.0	5.1	5.1	5.3	
151	5.1	5.3	5.5	4.6	4.9	5.1	
158	4.9	4.9	5.1	4.2	4.4	4.6	
164	4.4	4.6	4.6	3.7	4.2	4.4	
177	3.3	3.7	3.7	3.3	3.5	3.7	
190	2.0	2.2	2.4	2.4	2.9	3.1	
203	-	-	-	-	2.0	2.2	
216	-	-	-	-	-	-	





LIFTING CAPACITIES MAIN BOOM EXTENSION

13,900 lb

360°

85 %

41.0 ft Main boom							
Radius ft	Extension						
	29.9 ft			55.8 ft			
	0°	20°	40°	0°	20°	40°	
10	35.7	-	-	23.4	-	-	1,000 lb
12	35.7	-	-	22.5	-	-	
13	35.7	-	-	21.6	-	-	
15	34.8	-	-	20.7	-	-	
16	34.0	25.4	-	20.1	-	-	
20	31.7	23.8	-	18.5	-	-	
23	29.5	22.5	-	17.2	-	-	
26	27.8	21.4	17.2	16.1	-	-	
30	25.8	20.5	16.5	15.0	12.1	-	
33	24.0	19.6	16.1	14.1	11.5	-	
39	21.4	18.1	15.0	12.8	10.6	-	
46	19.2	16.8	14.1	11.5	9.7	8.4	
53	17.6	15.9	13.9	10.4	8.8	7.7	
59	16.3	15.9	-	9.5	8.4	7.5	
66	-	-	-	8.6	7.7	7.1	
72	-	-	-	7.9	7.3	6.8	
79	-	-	-	7.5	7.1	6.8	
85	-	-	-	-	6.8	-	
92	-	-	-	-	-	-	

139.8 ft Main boom							
Radius ft	Extension						
	29.9 ft			55.8 ft			
	0°	20°	40°	0°	20°	40°	
33	29.5	-	-	15.7	-	-	1,000 lb
39	27.8	-	-	14.8	-	-	
46	24.9	19.8	-	13.9	-	-	
53	21.8	19.0	15.4	13.0	10.1	-	
59	18.3	18.1	15.0	12.3	9.5	-	
66	16.1	16.5	14.6	11.7	9.3	-	
72	13.2	14.8	14.3	10.8	8.8	7.3	
79	10.8	12.1	13.2	9.9	8.4	7.1	
85	8.8	9.9	10.8	9.0	8.2	6.8	
92	7.1	8.2	8.8	7.5	7.7	6.8	
98	5.5	6.4	7.1	6.2	7.3	6.6	
105	4.2	5.1	5.7	5.1	6.6	6.4	
112	3.3	4.0	4.4	4.0	5.3	6.4	
118	2.2	2.9	3.3	2.9	4.2	5.3	
125	-	2.0	2.4	2.2	3.3	4.2	
131	-	-	-	-	2.4	3.3	
138	-	-	-	-	1.5	2.4	
144	-	-	-	-	-	-	
151	-	-	-	-	-	-	

168.0 ft Main boom							
Radius ft	Extension						
	29.9 ft			55.8 ft			
	0°	20°	40°	0°	20°	40°	
39	22.5	-	-	-	-	-	1,000 lb
46	21.8	-	-	12.3	-	-	
53	17.6	17.6	-	11.9	-	-	
59	15.7	16.3	14.3	11.2	-	-	
66	12.6	14.6	14.1	10.8	8.8	-	
72	9.9	11.7	13.2	9.7	8.4	-	
79	7.7	9.3	10.6	7.5	8.2	6.8	
85	5.7	7.3	8.4	6.0	7.7	6.8	
92	4.4	5.5	6.6	4.4	6.8	6.6	
98	3.1	4.2	5.1	3.1	5.3	6.4	
105	2.0	2.9	3.7	2.0	4.0	5.7	
112	-	2.0	2.6	-	2.9	4.4	
118	-	-	1.5	-	2.0	3.3	
125	-	-	-	-	-	2.4	
131	-	-	-	-	-	-	

196.9 ft Main boom							
Radius ft	Extension						
	29.9 ft			55.8 ft			
	0°	20°	40°	0°	20°	40°	
46	13.2	-	-	-	-	-	1,000 lb
53	13.2	-	-	8.6	-	-	
59	13.0	12.6	-	8.6	-	-	
66	9.9	12.1	11.9	8.4	-	-	
72	7.3	9.3	11.0	7.1	7.7	-	
79	5.3	7.1	8.6	5.1	7.5	-	
85	3.5	5.1	6.4	3.3	6.2	6.4	
92	2.2	3.5	4.9	2.0	4.6	6.2	
98	-	2.2	3.3	-	3.3	5.5	
105	-	-	2.0	-	2.0	4.0	
112	-	-	-	-	-	2.9	
118	-	-	-	-	-	1.8	
125	-	-	-	-	-	-	
131	-	-	-	-	-	-	
138	-	-	-	-	-	-	



**ALL TERRAIN CRANE
AC 140**

LIFTING CAPACITIES MAIN BOOM EXTENSION

86,000 lb

360°

85 %

41.0 ft Main boom		Extension					
Radius	82.0 ft			108.3 ft			
	0°	20°	40°	0°	20°	40°	
ft	1,000 lb						
16	19.8	-	-	-	-	-	
20	18.7	-	-	-	-	-	
23	17.6	-	-	16.3	-	-	
26	16.8	-	-	15.2	-	-	
30	15.9	-	-	14.3	-	-	
33	15.2	-	-	13.4	-	-	
39	13.9	10.8	-	11.7	-	-	
46	12.6	10.1	-	10.6	9.7	-	
53	11.5	9.5	7.9	9.5	8.8	-	
59	10.6	8.8	7.7	8.4	7.9	7.7	
66	9.7	8.4	7.5	7.7	7.3	7.1	
72	8.8	7.9	7.1	7.1	6.6	6.4	
79	8.2	7.5	7.1	6.2	6.2	6.0	
85	7.7	7.3	6.8	5.7	5.5	5.5	
92	7.1	6.8	6.6	5.3	5.1	5.1	
98	6.6	6.4	6.4	4.9	4.6	4.9	
105	6.2	6.2	6.4	4.4	4.4	4.4	
112	-	-	-	4.0	4.2	4.2	
118	-	-	-	3.7	3.7	4.0	
125	-	-	-	3.5	3.5	3.7	
131	-	-	-	3.3	3.3	-	
138	-	-	-	-	-	-	
144	-	-	-	-	-	-	
151	-	-	-	-	-	-	
158	-	-	-	-	-	-	

139.8 ft Main boom		Extension					
Radius	82.0 ft			108.3 ft			
	0°	20°	40°	0°	20°	40°	
ft	1,000 lb						
46	12.6	-	-	-	-	-	
53	12.1	-	-	9.5	-	-	
59	11.5	-	-	9.0	-	-	
66	11.0	8.8	-	8.4	-	-	
72	10.6	8.6	-	7.9	7.1	-	
79	10.1	8.2	7.1	7.5	6.8	-	
85	9.7	7.9	6.8	7.1	6.4	6.0	
92	9.3	7.7	6.6	6.6	6.2	5.7	
98	8.8	7.5	6.6	6.4	5.7	5.5	
105	8.6	7.3	6.4	6.0	5.5	5.1	
112	8.2	7.1	6.4	5.5	5.3	5.1	
118	7.9	6.8	6.2	5.3	4.9	4.9	
125	7.5	6.6	6.2	5.1	4.6	4.6	
131	7.3	6.6	6.2	4.9	4.4	4.4	
138	6.8	6.4	6.2	4.6	4.2	4.2	
144	6.6	6.2	6.0	4.4	4.2	4.0	
151	6.2	6.0	6.0	4.2	4.0	4.0	
158	5.7	5.7	5.7	4.0	3.7	3.7	
164	5.5	5.5	5.5	3.7	3.5	3.5	
177	4.6	4.6	4.9	3.5	3.3	3.3	
190	3.7	3.7	4.0	2.9	3.1	3.1	
203	3.3	3.3	-	2.2	2.6	2.9	
217	-	-	-	1.8	1.8	2.0	
230	-	-	-	1.5	1.5	-	
243	-	-	-	-	-	-	

168.0 ft Main boom		Extension					
Radius	82.0 ft			108.3 ft			
	0°	20°	40°	0°	20°	40°	
ft	1,000 lb						
53	9.7	-	-	-	-	-	
59	9.7	-	-	6.4	-	-	
66	9.5	-	-	6.4	-	-	
72	9.3	7.9	-	6.4	-	-	
79	9.0	7.7	-	6.2	-	-	
85	8.6	7.5	6.4	6.0	5.7	-	
92	8.4	7.3	6.4	6.0	5.5	-	
98	8.2	7.1	6.2	5.7	5.3	5.1	
105	7.9	6.8	6.2	5.5	5.1	4.9	
112	7.7	6.6	6.2	5.3	4.9	4.6	
118	7.3	6.6	6.0	5.1	4.6	4.4	
125	6.8	6.4	6.0	4.6	4.4	4.2	
131	6.4	6.2	6.0	4.4	4.2	4.2	
138	6.0	6.0	5.7	4.2	4.0	4.0	
144	5.5	5.5	5.5	4.0	4.0	4.0	
151	5.1	5.3	5.3	3.7	3.7	3.7	
158	4.6	4.9	5.1	3.5	3.5	3.5	
164	4.4	4.6	4.6	3.3	3.3	3.3	
177	3.5	4.0	4.0	2.9	2.9	3.1	
190	3.1	3.1	3.3	2.2	2.6	2.6	
203	2.2	2.6	2.6	1.5	2.0	2.2	
217	-	1.8	1.8	-	-	-	
230	-	-	-	-	-	-	

196.9 ft Main boom		Extension					
Radius	82.0 ft			108.3 ft			
	0°	20°	40°	0°	20°	40°	
ft	1,000 lb						
59	5.3	-	-	-	-	-	
66	5.3	-	-	2.9	-	-	
72	5.3	-	-	2.9	-	-	
79	5.1	-	-	2.9	-	-	
85	5.1	4.9	-	2.9	2.6	-	
92	4.9	4.9	-	2.6	2.6	-	
98	4.9	4.6	4.6	2.6	2.6	-	
105	4.6	4.4	4.4	2.6	2.6	2.6	
112	4.4	4.2	4.2	2.4	2.4	2.6	
118	4.2	4.0	4.0	2.2	2.4	2.4	
125	4.0	4.0	4.0	2.2	2.2	2.4	
131	3.7	3.7	3.7	2.0	2.0	2.2	
138	3.5	3.5	3.5	2.0	2.0	2.0	
144	3.3	3.3	3.3	1.8	1.8	2.0	
151	3.1	3.1	3.3	1.5	1.8	1.8	
158	2.9	2.9	3.1	-	1.5	1.8	
164	2.6	2.6	2.9	-	-	1.5	
177	2.0	2.2	2.4	-	-	-	
190	-	1.8	2.0	-	-	-	
203	-	-	-	-	-	-	
217	-	-	-	-	-	-	
230	-	-	-	-	-	-	
243	-	-	-	-	-	-	





WORKING RANGES MAIN BOOM EXTENSION

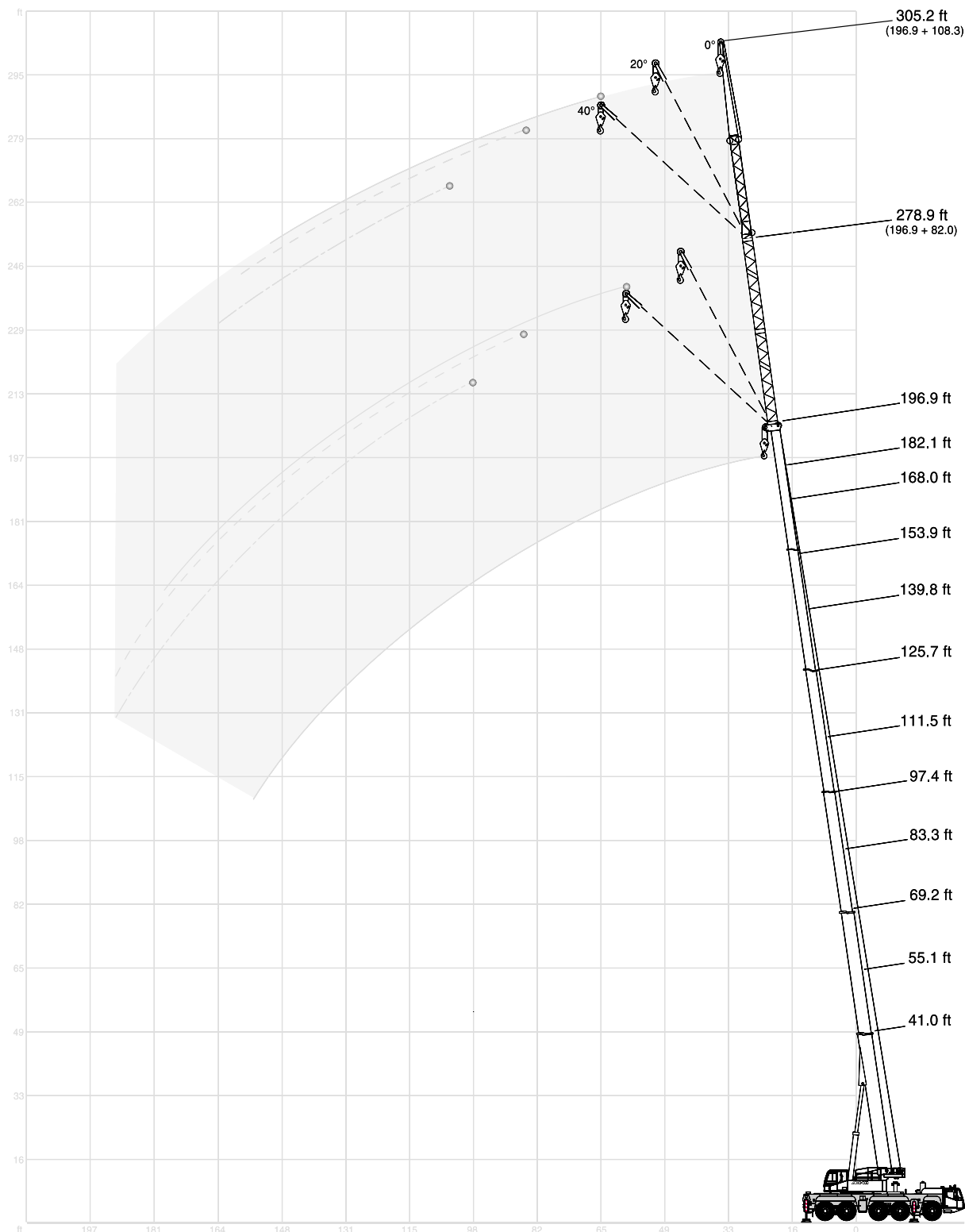

ALL TERRAIN CRANE **AC 140**

TECHNICAL DESCRIPTION

CARRIER

Drive / Steering	10 x 8 x 8.
Frame	Torsion-resistant box girder frame fabricated from high-strength fine grain structural steel.
Outriggers	4 telescopic outriggers, fabricated from fine grain structural steel, fully hydraulic horizontal and vertical extension.
Engine	Water-cooled 8 cylinder DaimlerChrysler diesel engine OM 502 LA, rating 380 kW (516 HP) at 1800 1/min, torque 2400 Nm at 1200 1/min, fuel tank capacity: 132 gallons.
Transmission	ZF AS-Tronic, electronically automated transmission with automatic clutch, 16 forward and 2 reverse speeds with integrated retarder, 2-range transfer case, cruise control.
Axles	Axles 2, 3, 4 and 5: driven, 1, 2, 4 and 5: steered. Transverse differential lockout control on axles 2, 3, 4 and 5. Longitudinal lockout control on axles 3 and 4.
Suspension	Hydro-pneumatic suspension on all axles, hydraulically lockable for on-site travel.
Wheels and tires	10 wheels fitted with 14.00 R 25 tires (Michelin or Bridgestone).
Steering	10 x 8, ZF dual-circuit semiblock mechanical steering with hydraulic booster and mechanical steering limiter, speed-dependent steering, 4th and 5th axles provide for independent rear axle steering.
Brakes	To EC directives. Sustained action brake: hydraulic retarder integrated into gearbox. Exhaust brake and constant choke valve.
Electrical equipment	24 V system.
Driver's cab	Highly comfortable ergonomic cab with clearly arranged dashboard, rubber mounted steel cab, corrosion-resistant powder coating with 2-pack top coat. 9.8 ft wide, 2 comfortable seats, with pneumatically sprung and heated driver's seat incl. head and arm rests, and three-point seat belts, vertically adjustable steering wheel, safety glass used throughout, electric windows, heated and electrically adjustable mirrors, windscreen defroster fans, engine-dependent hot water heater, electric windscreen washer and wiper, roller blinds, radio with CD player, stowage compartment, air-conditioning.

SUPERSTRUCTURE

Engine	Water-cooled 4 cylinder DaimlerChrysler diesel engine OM 904 LA, rating 130 kW (177 HP) at 1800 1/min, torque 630 Nm at 1200 1/min, fuel tank capacity: 60 gallons (on superstructure).
Hydraulic system	Two variable displacement axial piston pumps with automatic power control enabling the operator to engage four independent working movements simultaneously, separate pump for slewing. Hydraulic oil cooler included as standard. Reservoir capacity: 206 gallons.
Hoist	Fixed displacement axial piston hydraulic motor, hoist drum with integrated planetary gear reducer, and spring-applied multi-disk brake. Hydraulic brake, drum rotation indicator.
Slew unit	Hydraulic motor with planetary gear reducer, pedal-operated brake, joystick-actuated free swing, spring-applied holding brake.
Boom elevation	1 differential cylinder with automatic lowering brake valve.
Crane cab	Highly comfortable cab with sliding door, roof window and large hinged windscreen; safety glass used throughout; sprung and hydraulically damped operator's seat with head and arm rests; wiper for windscreen and roof window; self-contained hot water heater with timer and 'Heizmatic' for sensitive heat flow control; dashboard with instrumentation and crane controls, e.g. drum rotation indicator for hoists I and II, load moment limiter, outrigger loading indicator; 2 working lights, air-conditioning. The crane cab can be tilted back hydraulically 18°.
Main boom	Boom base and 5 telescopic sections fabricated from fine grain structural steel; anti-deflection Demag Ovaloid profile.
Counterweight	86,000 lb, divisible, hydraulically stowable on carrier.
Safety devices	Electronic safe load indicator with graphic display and touchscreen, digital readout for hook load, rated load, boom length and angle, radius, monitoring code to assist in trouble shooting, and analog display to indicate capacity utilization in %, integrated control system for boom telescoping, display for duty charts and theoretical and actual outrigger loading. Working range limitation to certain, pre-defined slew angles, heights and radii („virtual walls“) included as standard.

OPTIONAL EQUIPMENT

Runner	4.9 ft, 2-sheaves.
Twist arrestor	To untwist the hoist ropes.
Heavy lift attachments	The max. lifting capacity of the standard crane without heavy lift attachment is 170,900 lb (5 sheaves on boom head).
Emergency control	Interface for emergency control to recover small loads, incl. transformer. With hydraulic motor and hydraulic pump available on request.
Warning light	For main boom and attachments.
Rooster sheave	Sheave on boom head folding to the side of the boom, for single-line operation.
Wheels and tires	16.00 R 25, 17.5 R 25 and 20.5 R 25.
Hoist 2	Fixed displacement axial piston hydraulic motor, hoist drum with integrated planetary gear reducer, and spring-applied multi-disk brake. Hydraulic brake, drum rotation indicator.
Main boom extension	1 or 2-part foldaway jib, 29.9 ft or 55.8 ft, can be extended to 82.0 ft and 108.3 ft. 0°, 20° and 40° offset.
Further options on request!	





NOTES TO LIFTING CAPACITY

Ratings are in compliance with ISO 4305 and DIN 15019.2 (test load = 1.25 x suspended load + 0.1 x dead weight of boom head).
Weight of hook blocks and slings is part of the load, and is to be deducted from the capacity ratings.

Crane operation with main boom is permissible up to a

wind pressure of: 1.25 lb/ft²

wind speed of: 32 ft/s

Consult operation manual for further details.

Note: Data published herein is intended as a guide only and shall not be construed to warrant applicability for lifting purposes.
Crane operation is subject to the computer charts and operation manual both supplied with the crane.

KEY



Counterweight



Lifting capacities on outriggers 360°

„D“

